

Development and Future of Optical Fiber Related Technologies

Shigeru TOMITA^{†a)}, *Member*

SUMMARY The history of optical fiber and optical transmission technologies has been described in many publications. However, the history of other technologies designed to support the physical layer of optical transmission has not been described in much detail. I would like to highlight those technologies in addition to optical fibers. Therefore, this paper describes the history of the development of optical fiber related technologies such as fusion splicers, optical fiber connectors, ribbon fiber, and passive components based on changes in optical fibers and optical fiber cables. Moreover, I describe technologies designed to support multi-core fibers such as fan-in/fan-out devices.

key words: *optical fiber, fusion splicer, optical fiber connector, multi-core fiber, fan-in and fan-out device*

1. Introduction

Optical fiber was invented in early 1970. In the early stages, multi-mode fibers were used, however, since the mid 1980s single-mode fibers have largely been employed. Optical fiber and optical transmission techniques have subsequently been modified to increase both transmission capacity and distance. Their history has been described in many publications. However, the history of other technologies designed to support the physical layer of optical transmission has received much less attention. In this work, I highlight these technologies along with optical fiber. Optical fiber related technologies have been modified based on the changes made to optical fiber and cable structures. For example, ribbon fibers were introduced in 1985 to make it possible to install high-count optical fiber cables, and multi-fiber jointing technologies were introduced at the same time.

In 2010, the development of multi-core fiber started, because it was expected that there would be a limit to the increase in transmission capacity that could be achieved by modifying transmission technologies. A lot of new technologies will be required if we are to realize high capacity transmission using multicore fibers. Fan-in/fan-out devices are described, which are an important technology with which to activate multi-core fibers. This paper, describes the history of optical fiber related technologies based on the changes in optical fiber geometrical structures.

2. Coated Single-Mode Optical Fiber and Related Technologies

2.1 Optical Fiber and Cable Structure

Optical fibers can transmit high bit rate signals, and so in the early stages it was thought that optical fiber would be used in trunk lines. One optical fiber can transmit over 10 thousand phone calls suggesting that only a few fibers would be required for one trunk link. In this era (1978–1985), optical fiber coated with an outer diameter of 0.9 mm as shown in Fig. 1 was used [1]. A coated optical fiber consists of an optical fiber with two coating layers. The inner coating layer is called the primary coating and it works as a buffer layer. The outer coating layer is called the secondary coating and it protects optical fibers from the effects of the outer environment.

Figure 2 shows a cross-section of 10-optical fiber cable [2]. It consists of optical fibers, a tensile member, laminated aluminum (LAP) tape () and a sheath.

The tensile member is used to protect optical fibers from a tensile load during installation work. At that time, to prevent water penetration, optical fiber cables were filled with high-pressure gas in the same way as metallic cables. LAP tape works to protect the sheath from such high-pressure gas. The sheath protects the cable elements from the effects of the outer environment.

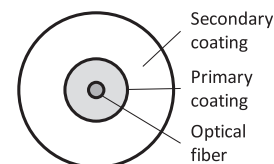

Fig. 1 Coated optical fiber.

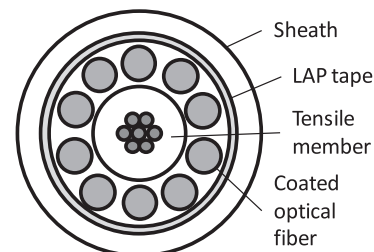

Fig. 2 10-optical fiber cable.

Manuscript received September 23, 2016.

Manuscript revised January 27, 2017.

Manuscript publicized March 22, 2017.

[†]The author is with NTT-AT, Tsukuba-shi, 305-0805 Japan.

a) E-mail: shigeru.tomita@ntt-at.co.jp

DOI: 10.1587/transcom.2016PF10003

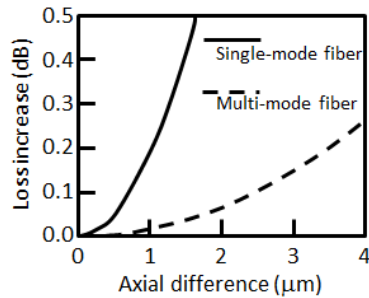

Fig. 3 Jointing loss of optical fibers.

2.2 Optical Fiber Fusion Splicer for Coated Fibers

Three technologies have been used widely to join optical fibers, namely fusion splicers, optical fiber connectors and optical fiber mechanical splices. This section describes the development history of fusion splicers and optical fiber connectors.

When forming optical joints, the most important issue is to minimize optical jointing loss. There are several causes for optical jointing loss including differences in optical axis position, the tilt of the optical axes, and differences in mode field diameters. Firstly, we should consider differences in optical axis position. When the difference is large, it is impossible to join optical fibers with a low loss. When the mode field diameters of the multi-mode fiber and single-mode fiber are 50 and 9 μm , respectively, the jointing losses caused by the difference in the optical axis positions calculated by Marcuse's equation are as shown in Fig. 3 [3]. A human hair is about 100 μm in diameter. With multi-mode fiber, when the optical axis difference between the positions of two optical axes is about 1/30 the diameter of a human hair, the optical loss is 0.2 dB. With single-mode fiber, when the optical axis difference between the positions of two optical axes is about 1/100 of human hair diameter, the optical loss is also 0.2 dB. This means that very precise control of the positions of the optical axes is required.

The fusion splice process is as follows.

- (1) remove jacketing materials from optical fibers
- (2) align two optical fibers
- (3) melt optical fiber with high temperature heat source
- (4) mate melted optical fibers
- (5) fix optical fibers together by cooling
- (6) reinforce jointed section with protection material

After removing the jacketing materials, optical axis alignment is accomplished with a second process to achieve a low splicing loss. To realize optical axis alignment, we should determine the core position in the optical fiber precisely. The direct core observation method was developed for this purpose.

With this method, an illumination light source is placed at one side of the optical fiber and a camera is placed on the opposite side, as shown in Fig. 4. We can estimate the core position in the fiber by capturing images of the light power distribution through the optical fiber in a few different

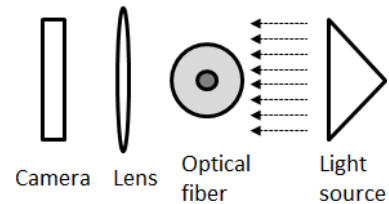

Fig. 4 Core position measurement.

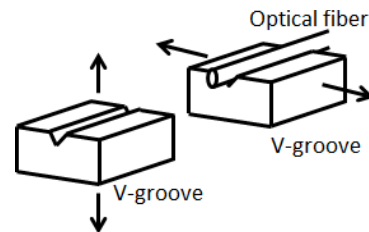

Fig. 5 Alignment with movable V-groove.

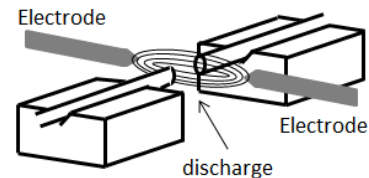

Fig. 6 Heating optical fibers by electric discharge.

directions [4].

On the basis of the above information, we should align two optical fibers, and so a movable V-groove had been developed for this purpose. V-grooves, which accommodate optical fibers, must be moved precisely to align two optical fiber cores. One side of a V-groove can be moved in the X-direction, and the other can be moved in the Y-direction, and by using this mechanism two optical fibers can be aligned, as shown in Fig. 5.

The alignment processes described above were required in the early years when the optical fiber manufacturing process could not be well controlled. Today, optical fiber geometry is well controlled. The difference between the centers of an optical fiber and a core can be controlled at less than 1 μm . The optical axis can be aligned by fitting together the outer circles of two optical fibers. Therefore, when a splicing loss of about 0.1 dB is allowable, no alignment process is required. When a lower splicing loss is needed, the alignment mechanism is still used.

Several kinds of high temperature heat source have been investigated for melting optical fibers. Fusion splice machines are frequently used in the field, and so portability, low power consumption and safety are required. From these viewpoints, a high frequency discharge device has been selected as a high temperature source. (Shown in Fig. 6).

To reinforce the jointing section of optical fibers, the combination of a heat shrinking jacket, hot melt adhesive and a tensile strength member is commonly used. For single-fiber splicing, a stainless rod has been used as a tensile strength

member to realize long-term reliability and a low coefficient of thermal expansion. This type of optical fiber fusion splicer was introduced in 1985.

2.3 Optical Fiber Connector for Mono-Coated Fiber

Until of the mid-1980s, the FC-connector was frequently used as an optical connector for single-mode fibers. However, the FC-connector posed the following problems.

- (1) Space is needed for connection and disconnection.

An FC connector requires a space of some 30 mm between two connector plugs to allow a coupling nut to be rotated with the fingers.

- (2) High ferrule cost

A ferrule consists of a ceramic capillary with a small hole precisely positioned at the ferrule center and a stainless cylinder. A ceramic capillary was installed into a stainless cylinder, and both parts were processed using a high precision.

- (3) High weight

Almost all the connector components were metal products.

In 1985, NTT considered that optical fibers would be installed in access networks in the late 80s. When optical fibers are installed in access networks, many of these fibers are connected in telephone offices, building cabinets and cable jointing closures. Therefore, techniques are need to realize lightweight connections in small spaces at a low cost. This led to the development of the subscriber connector (SC) [5]. The SC connector has three special characteristics. The first is the adoption of a push-pull mechanism for coupling and de-coupling connectors. This mechanism facilitated operation in a small space and reduced the operation time. The second is that a ferrule is made only of ceramic materials. The third is that almost the elements except for a ferrule are made with plastic molding. This reduces costs. Figure 7 shows the plug and adapter of an SC connector. Figure 8 shows the coupling and decoupling mechanism of the SC connector.

When inserting the plug into the adapter, Slope A knocks Ledge C, which is located at the tip of the cantilever in the adaptor. Then Cantilever B opens as Ledge C moves upward along with Slope A. By further inserting the plug into the adapter, Ledge C moves down along Slope E, and the cantilever returns to its original position and snaps Latch D into Concave F in the plug. The completion of coupling can be confirmed by the snap that can be heard when the latch is inserted into the concave.

When pulling the plug from the adapter, Slope E knocks Ledge C, which pushes up the cantilever. Consequently, Cantilever B opens and unlocks Latch D from Concave F to uncouple the plug.

Moreover, NTT planned to transmit analog video signals through optical fibers in subscriber lines. For this purpose, optical connectors require a return loss of more than

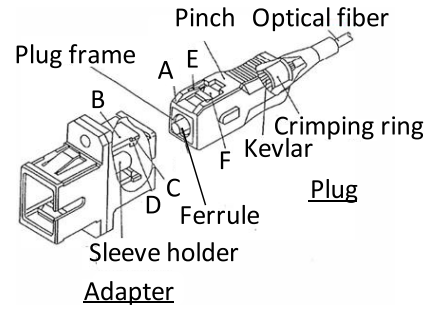

Fig. 7 Structure of SC-connector.

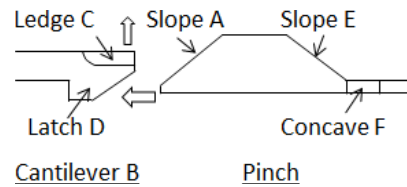

Fig. 8 Insertion of plug.

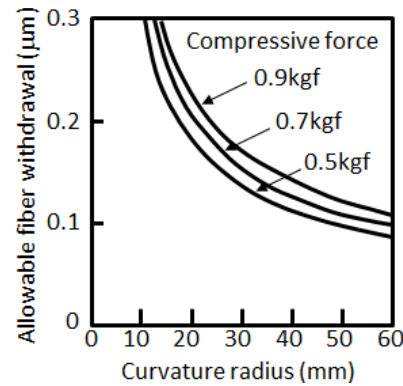

Fig. 9 Allowable fiber withdrawal.

25 dB. To reduce the return loss of a connector, we must suppress the Fresnel reflection that is generated by a refractive index difference between an optical fiber and air. There are two ways to suppress Fresnel reflection. The first is to use index-matching gel. The second is to adopt a physical contact approach. When using index matching gel, we have to apply and remove the gel whenever connecting and re-connecting. This makes operation work complicated. Therefore, there was an attempt to develop a mechanism to ensure physical contact with a zirconia ferrule. First, it was decided that the two ferrule ends of optical fibers should be convex spherically polished. This structure makes physical contact between fiber cores easier by locating the ferrule (fiber) centers at the top of the end-faces. There was another problem, namely that the fiber surface often withdrew from the ferrule end as the temperature changed or due to a difference in surface polishing, because the optical fiber and ferrule materials differed. To realize stable physical contact even if the optical fiber is withdrawn from the ferrule end, it is necessary to apply compressive force to both ferrule ends.

Figure 9 shows the relationship needed to realize stable physical contact between the fiber withdrawal, compressive force and the curvature radius of an optical fiber end-face. The SC connector was standardized in June 1993 by the International Electrotechnical Commission (IEC). In 1999, the SC connector share of the optical fiber connector market exceeded 70%. Although various other optical fiber connectors were subsequently introduced, the SC connector share was still about 46% in 2013.

3. Ribbon Fibers and Related Technologies

3.1 Ribbon Fiber and Cable Structure

Optical fiber ribbon is a kind of coated fiber. Figure 10 shows a cross-section of an optical fiber ribbon (four fiber ribbon) [6]. Four coated optical fibers are unified by using an outer coating material. Each coated optical fiber is 0.25 mm in diameter, and so the distance between adjacent optical fibers is 0.25 mm.

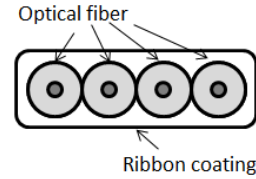

Fig. 10 Cross-section of 4-optical fiber ribbon.

The slotted rod cable was invented to accommodate the optical fiber ribbon. For example, the cross-section of 1000-optical fiber cable is shown in Fig. 11 [6]. The cable consists of one hundred and twenty-five 8-fiber ribbons, a tensile member, LAP tape and a sheath. Five 8-fiber ribbons are stacked and accommodated in each slot. Each slotted rod has five slots, giving the cable a total of twenty-five slots.

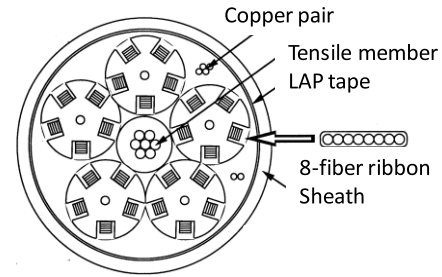

Fig. 11 1000-optical fiber cable.

A few years later, a new optical fiber cable structure was developed. Figure 12 shows a cross-section of a 1000-optical fiber water blocking cable. Single slotted rod and water blocking tape have been applied newly to increase fiber density [7].

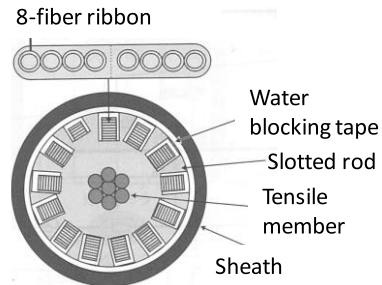

Fig. 12 1000-optical fiber water-blocking cable.

With metallic cables, a short circuit may be caused if they are penetrated by water. With optical fiber cables, this kind of immediate problem does not occur. However, when optical fibers are submerged for a long time, it is known that their long-term reliability will be degraded. To prevent this degradation, water-blocking materials have been developed for cables. Figure 13 shows the structure of water blocking tape [7].

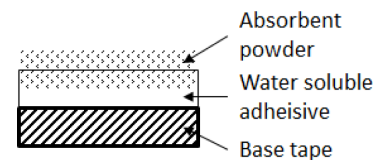

Fig. 13 Water-blocking tape.

A water-blocking tape consists of absorbent powder whose volume increases as it absorbs water, water-soluble adhesive and a base tape. The water soluble adhesive holds the absorbent powder in place. When water seeps into the cable as a result of cable sheath damage, the water-soluble adhesive dissolves. Then the absorbent powder is released and spreads rapidly into the empty spaces in the cable. The absorbent powder combines with water to form a gel and is able to absorb 1000 times its own volume. The empty spaces are filled as the volume of the absorbent powder increases. Then water penetration is halted once the empty spaces are filled. This mechanism has been installed in optical fiber cables in Japan since 1989.

3.2 Multi-Fiber Fusion Splicing

It is difficult to equip alignment devices for each coated

fiber in a fusion-splicing machine. A self-alignment effect realized by surface tension minimization has been utilized to align each fiber. When a liquid solidifies, the surface is smoothed by surface tension. When two melted glass rods are mated, their surfaces have already been smoothed during the solidification process by surface tension. This means that the center axes of two glass rods are aligned.

Figure 14 shows this process. First, the end sections of two optical fibers are mated by moving one fiber toward the other. Second, the two mated fibers are melted with a high-frequency discharge. Finally, the two fibers are solidified to minimize the gap between their two surfaces. (This corresponds to aligning the centers of the two fibers) When using this method, deformation of the core and cladding structure may remain around the solidified end-faces. However, the loss caused by this deformation is much lower than that caused by misalignment. By using this effect, when the

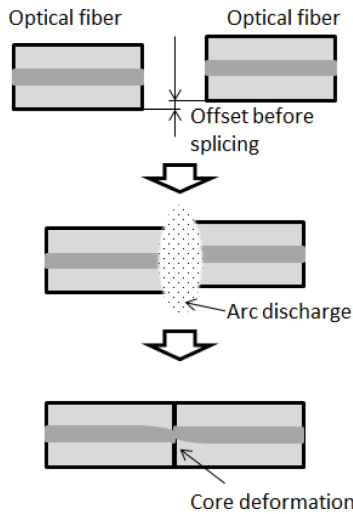

Fig. 14 Self-alignment effect by surface tension minimization.

core is positioned in the center of fiber, low loss splicing is achieved without the need for an alignment mechanism in the fusion splicer. Of course, the core should be located very near the center of the optical fiber. Therefore, the control of the cross-section geometry of the fiber during the manufacturing process should be refined.

In the early 1980s, the mean difference between the core center and the cladding center of single-mode fiber was from 2 to 3 μm . In 1985, when optical fiber ribbons using single-mode fibers became available, the mean difference was about 1 μm . This kind of improvement in the manufacturing process is an important factor in the realization of optical fiber ribbon jointing by fusion splicing. This type of multi-optical fiber fusion splicer was introduced in 1987 [8].

3.3 Multi-Fiber Connector

As with the demand for a fusion splicer, a multi-fiber connector was required once optical fiber ribbon had been introduced. In the first stage, the ferrule for a multi-fiber connector consisted of a combination of materials, for example metal and plastic. However, following the same requirements as those for the SC connector, a ferrule made of a single material was invented. A high precision plastic molding technique was developed to achieve a ferrule for a multi-fiber connector. Figure 15 shows the structure of a multi-fiber connector called an MT-connector [9]. The MT-connector consists of two-ferrules, two guide pins and a clamp spring. The ferrules are aligned with two guide-pins and it is held together with a clamp spring. The ferrules can be disconnected once the clamp spring and guide pins have been removed. Index-matching material is used between the ferrule end-faces. The connection loss depends on the precision of the molded ferrule.

In the mid 1980s, it was difficult to mold plastic ferrules with micrometer precision. Therefore, a die and plastic material that enabled high precision molding were developed for this connector. In the early stages, precise connector

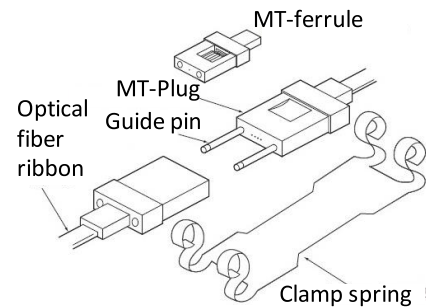

Fig. 15 Structure of multi-fiber connector.

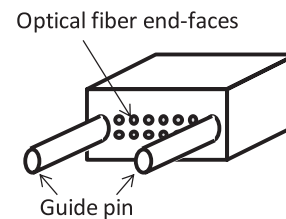

Fig. 16 Structure of high count fiber connector.

molding was applicable only to multi-mode fibers. However, by improving the molding processes and materials, the MT-connector became applicable to single-mode fiber by the end of the 1980s. Today, multiple row MT-connectors (as shown in Fig. 16) have been developed and standardized. Several tens of fibers can be accommodated in a ferrule.

4. Variation in Single-Mode Optical Fibers

After 1000-optical fiber cable was developed, the transmission capacity was increased as transmission systems evolved. For example, the signal bit-rate was increased to 100 G-bit and wavelength division multiplexing (WDM) was used to increase the number of channels for one fiber. In addition, quadrature amplitude modulation (QAM) techniques applicable to optical fiber transmission were developed.

At the same time, many kinds of optical fibers had been developed and used as recommended by the International Telecommunication Union Telecommunication (ITU-T) Standardization Sector. As these optical fibers will be familiar to readers, I shall describe them very briefly.

Single-mode fiber, which was the first to be used in the network, is a single-mode optical fiber that has a zero-dispersion wavelength around 1310 nm. Its characteristics are described in ITU-T G.652 [10]. When the refractive index distribution is simple and those of the core and cladding are flat, the zero-dispersion wavelength is around 1310 nm. Therefore, this type of optical fiber is easy to design and produce. Even today, market share of G.652 fibers remains high. Next, a dispersion-shifted, single-mode optical fiber (as described in ITU-T G.653 [11]) was introduced. Its attenuation in Si-glass is the lowest at a wavelength of around 1550 nm. A low attenuation is very useful for long-haul transmission systems. Therefore, the zero dispersion wavelength was shifted to 1550 nm, by appropriately designing

the refractive index distribution of the core and cladding. A third type of fiber was also designed to be applied to long-haul transmission. It is called cut-off shifted single-mode optical fiber (ITU-T G.654 [12]). This type of optical fiber was designed to be applied to submarine cables. For submarine cable application, it is desirable to increase the distance between adjacent repeaters to reduce the number of high price repeaters. Based on this aim, pure silica glass is used as the core material, and a rare earth is doped in the cladding glass to reduce the refractive index. These types of fibers are still being developed to realize lower attenuation. G.653 and G.654 fibers have been used to increase the transmission distance by using 1550 nm wavelength light. The next two types of fibers were designed and introduced to increase the number of lightwaves in a certain wavelength region. Those fibers are designed to suppress nonlinear effects. When the number of lightwaves is large and the total power of the optical light is high, nonlinear effects may occur and may impair the transmission characteristics. Non-zero dispersion-shifted single-mode optical fiber (ITU-T G.655 [13]) has chromatic dispersion coefficient whose absolute value is greater than some non-zero values throughout the 1530 nm to 1565 nm wavelength range to reduce any increase in nonlinear effects, which are particularly deleterious in dense wavelength division multiplexing systems. Non-zero dispersion fiber for wideband optical transport (ITU-T G656 [14]) has a chromatic dispersion coefficient with a positive value that is greater than some non-zero values throughout the 1460–1625 nm wavelength range that it is anticipated will be used.

The last type of fiber is especially designed for access network cable applications. It is called a bending-loss insensitive single-mode optical fiber (G.657 [15]). This type of fiber has almost the same characteristics as G.652 fibers except for its bending characteristics. As FTTH services expand, optical fibers are being installed in houses and SOHOs. In such locations, we must be able to bend optical fibers with a small diameter. This type of fiber is designed to meet this need.

5. Multi-Core Optical Fiber

Between 1990 and 2010, by combining the transmission technologies and new fibers described in Section 4, the transmission capacity of one fiber been raised to 100 T bit/sec. However, during this period there were no major changes in fiber related technologies, such as connector and fusion splicers. This is because the connectors and fusion splicers designed for simple single-mode fibers (zero dispersion wavelength of 1310 nm, ITU-T G.652) have been able to be used with the new types of fibers.

In 2010, the National Institute of Information and Communications Technology (NICT) announced the start of research and development on innovative optical fiber technologies. This research is being undertaken because increasing transmission capacity by modifying transmission technologies was approaching its limit. NTT, optical fiber and ca-

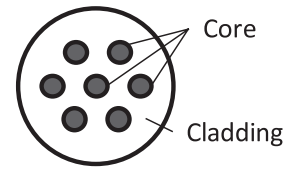

Fig. 17 Cross-section of multi-core fiber.

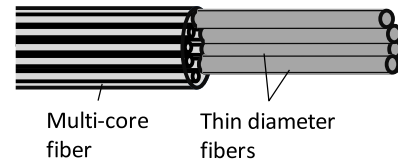

Fig. 18 Fi/Fo device using thin diameter fibers.

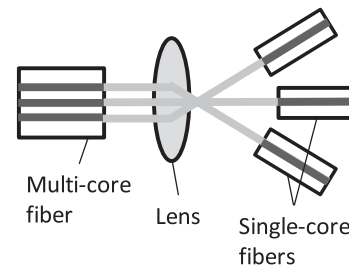

Fig. 19 Fi/Fo device using free optics.

ble makers, optical fiber connector makers and universities have joined this project, and many developments have been practically introduced. Multi-core optical fiber is one such development. The cross-section of a multi-core optical fiber is shown in Fig. 16 as an example. There are seven cores in the fiber, protected by cladding.

5.1 Fan-In (Fi) and Fan-Out (Fo) Devices

Fan-in (Fi) and Fan-out (Fo) devices are important for use with multi-core fibers. By using Fi devices, light from a light source can be introduced correctly into each fiber and by using Fo devices light can be led from each fiber to receivers. Some types of Fi and Fo devices are shown in Figs. 18, 19 and 20.

Figure 18 is a diagram of a Fi/Fo device that uses thin diameter fibers [18]. We can introduce and lead out the light to/from each core by using optical fibers with a diameter that is sufficiently small to avoid interference with adjacent cores in the multi-core fiber. Tapered fibers may be used in place of small diameter fibers [19]. The end-section of normal optical fiber is been deformed by a thermal source to make its end diameter small enough not to interfere with adjacent cores in the multi-core fiber. If deformation occurs over a short distance, optical attenuation will increase. Therefore, the diameter of the optical fiber is reduced over a sufficiently long distance to avoid affecting the optical transmission characteristics.

Figure 19 shows a diagram of a Fi/Fo device that uses free optic system [20]. The beam directions are controlled to

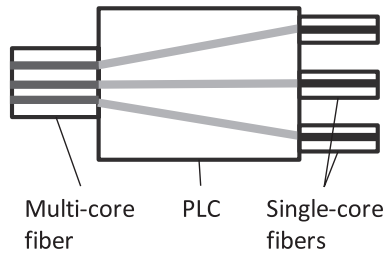

Fig. 20 Fi/Fo device using PLC.

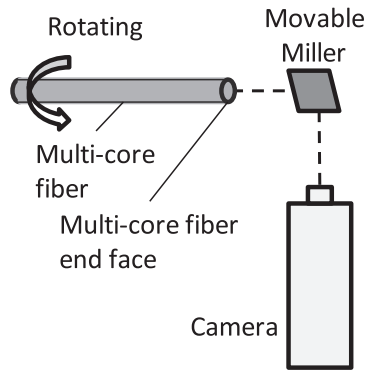

Fig. 21 Fiber end-face control system using a movable mirror and a camera.

fit each fiber core by a lens that is located between the end-faces of multi-core and single-core fibers. In some cases, two or more lenses may be combined to construct this type of system.

Figure 20 is a diagram of a Fi/Fo device that uses a planar lightwave circuit (PLC) [21]. With the PLC, which is located between the end-face of multi-core and single-core fibers, light is guided to each fiber core. In some cases, two or more PLCs may be stacked and combined when constructing this type of system.

5.2 Jointing Technologies for Multi-Core Fibers

Connector and fusion splicing machine technologies have been reported for joining multi-core fibers. These devices are designed based on technologies used for polarization maintaining fibers (PMF). Even when using PMF, the end-faces of the two fibers should be precisely controlled to match the refractive index distribution geometries. For example, Fig. 21 shows a fiber end-face positioning system using a movable mirror and a camera. The fiber end-face geometry is viewed with a camera via a mirror, and then the fiber is rotated in the appropriate direction. Then a connector is used to fix the fiber to the ferrule. With a fusion splicer, two fibers are mated and spliced.

5.3 Multi-Core Fiber Transmission Experiments

Since 2013, there have been many reports of transmission experiments using multi-core optical fibers. The cores are not limited to single-mode core; those that can transmit a

few modes have also been adopted. And coupled-core transmission, which uses multiple cores for one signal, has also been invented in 2015, NICT used of single-mode cores and reported a 2.15 Pb/s transmission through a 22-core homogeneous single-mode multi-core fiber [22]. And in 2016 NTT reported the transmission of PDM-16QAM signals over 1600 km using 32-core heterogeneous single-mode multi-core fiber [23]. As regards a few mode core, in 2016 KDDI reported 665 and 947b/s/Hz SDM/WDM transmissions over 6-mode 19-core fiber using DP16 QAM/64QAM signals [24]. In 2016 Bell Labs reported a multiple core transmission experiment in a paper entitled “Long-distance transmission over coupled-core multicore fiber” [25]. Multi-core fiber related topics are currently hot topics among optical transmission researchers.

6. Future

The demand for high-speed transmission has been increasing year by year, especially in data centers. Cables that accommodate over 1000 optical fibers are used to meet this demand. As a result, the maximum fiber count is now 12 when using fusion splicing. To increase the fiber count using fusion splicing, we require a heat source that can heat a wide region with high stability. The fiber count of a multi-fiber connector has reached 20–40 for single-mode fiber. Recently, research on high fiber count connectors has frequently been reported in technical papers and journals. In the near future, we can expect the fiber count to reach around a hundred.

We described multi-core fiber related technologies. However, research and development on multi-core fiber has just started. Therefore, greater research and development efforts will be needed before we can install these technologies in actual transmission systems. In other words, this area is home to many research themes. We can anticipate there being many reports on optical transmission related issues in the future.

Acknowledgments

I thank Dr. Hiroshi Naruse, Dr. Masayuki Shigematsu and Dr. Fumihiko Yamamoto who gave me the opportunity to write this paper. I also thank Dr. Takashi Matsui who helped on writing this paper.

References

- [1] K. Ishida et al., “Development of optical fiber cables for middle and low capacity optical transmission,” *Tsuken-Jippou*, 30-9, pp.2167–2179, 1981 (in Japanese).
- [2] M. Kawase, et al., “Design and performance of optical subscriber cables,” *Rev. of ECL*, 32, 4, pp.626–635, 1984.
- [3] D. Marcuse, “Loss analysis of single-mode optical fiber splice,” *Bell Syst. Tech. J.*, vol.56, no.5, pp.703–718, 1977.
- [4] O. Kawata, K. Hoshino, and K. Ishihara, “Low-loss single-mode optical fiber splicing technique using core direct monitoring,” *Electron. Lett.*, vol.19, no.24, pp.1048–1049, 1983.
- [5] E. Sugita, K. Iwasa, and T. Shintaku, “Design of high-performance push-pull coupling optical fibre connectors,” *IEICE Trans. Electron.*

(Japanese Edition), vol.J70-C, no.10, pp.1405–1414, Oct. 1987.

- [6] M. Kawase, T. Fuchigami, M. Matsumoto, S. Nagasawa, S. Tomita, and S. Takashima, "Subscriber single-mode optical fiber ribbon cable technologies suitable for midspan access," *J. Lightw. Technol.*, vol.7, no.11, pp.1965–1681, 1989.
- [7] S. Tomita, F. Ashiya, and M. Kawase, "1000-fiber water-blocking cable," *IEICE Trans.*, vol.E73, no.9, pp.1511–1516, 1990.
- [8] T. Haibara, S. Nagasawa, M. Matsumoto, and K. Kawase, "Single-mode multi-fiber technique for high density high-count subscriber cables," 37th IWCS, pp.576–585, 1988.
- [9] S. Nagasawa, H. Furukawa, M. Makita, and H. Murata, "Mechanically transferable single-mode multifiber connector," *OEC'89*, pp.48–49, 1989.
- [10] ITU-T Recommendation G.652.
- [11] ITU-T Recommendation G.653.
- [12] ITU-T Recommendation G.654.
- [13] ITU-T Recommendation G.655.
- [14] ITU-T Recommendation G.656.
- [15] J. Sakaguchi, W. Klaus, J.M.D. Mendinueta, B.J. Puttnam, R.S. Luis, Y. Awaji, N. Wada, T. Hayashi, T. Nakanishi, T. Watanabe, Y. Kokubun, T. Takahata, and T. Kobayashi, "Realizing a 36-core, 3-mode fiber with 108 spatial channels," *OFC 2015 Postdeadline Papers*, Th5C.2, 2015.
- [16] K. Igarashi, D. Souma, Y. Wakayama, K. Takeshima, Y. Kawaguchi, T. Tsuritani, I. Morita, and M. Suzuki, "114 space-division-multiplexed transmission over 9.8-km weakly-coupled-6-mode uncoupled-19-core fibers," *OFC 2015 Postdeadline Papers*, Th5C.4, 2015.
- [17] T. Sakamoto, T. Matsui, K. Saitoh, S. Saitoh, K. Takenaga, T. Mizuno, Y. Abe, K. Shibahara, Y. Tobita, S. Matsuo, K. Aikawa, S. Aozasa, K. Nakajima, and Y. Miyamoto, "Low-loss and low-DMD few-mode multi-core fiber with highest core multiplicity factor," *OFC 2015 Postdeadline Papers*, Th5A.4, 2015.
- [18] K. Watanabe, T. Saito, and M. Shiino, "Development of fiber bundle type fan-out for 19-core multicore fiber," *Proc. OECC 2014*, Mo1E2, 2014.
- [19] B. Zhu, T.F. Taunay, M.F. Yan, J.M. Fini, M. Fishteyn, E.M. Monberg, and F.V. Dimarcello, "Seven-core multicore fiber transmissions for passive optical network," *Opt. Express*, vol.18, no.11, pp.11117–11122, 2010.
- [20] H. Arao, O. Shimakawa, M. Harumoto, T. Sano, and A. Inoue, "Compact multi-core fiber fan-in/out using GRIN lens and microlens array," *Proc. OECC 2014*, Mo1E1, 2014.
- [21] T. Watanabe, M. Hikita, and Y. Kokubun, "Laminated polymer waveguide fan-out device for uncoupled multi-core fibers," *Opt. Express*, vol.20, no.24, pp.26317–26325, 2012.
- [22] B.J. Puttnam, R.S. Luis, W. Klaus, J. Sakaguchi, J.-M. Delgado Mendinueta, Y. Awaji, N. Wada, Y. Tamura, T. Hayashi, M. Hirano, and J. Marcianti, "2.15 Pb/s transmission using a 22 core homogeneous single-mode multi-core fiber and wideband optical comb," *Proc. ECOC 2015*, no.1056, 2015.
- [23] T. Mizuno, K. Shibahara, H. Ono, Y. Abe, Y. Miyamoto, F. Ye, T. Morioka, Y. Sasaki, Y. Amma, K. Takenaga, S. Matsuo, K. Aikawa, K. Saitoh, Y.-M. Jung, D.J. Richardson, K. Pulverer, M. Bohn, and M. Yamada, "32-core dense SDM unidirectional transmission of PDM-16QAM signals over 1600 km using crosstalk-managed single-mode heterogeneous multicore transmission line," *OFC 2016 Postdeadline Papers*, Th5C.3, 2016.
- [24] D. Soma, Y. Wakayama, S. Beppu, K. Igarashi, T. Tsuritani, H. Taga, I. Morita, and M. Suzuki, "665 and 947 b/s/Hz ultra-highly aggregate-spectral-efficient SDM/WDM transmission over 6-mode 19-core fibre using DP-16QAM/64QAM signals," *ECOC 2016 Postdeadline Papers*, 2016.
- [25] R. Ryf, J.C. Alvarado, B. Huang, J. Antonio-Lopez, S.H. Chang, N.K. Fontaine, H. Chen, R.-J. Essiambre, E. Burrows, R. Amezcua-Correa, T. Hayashi, Y. Tamura, T. Hasegawa, and T. Taru, "Long-distance transmission over coupled-core multicore fiber," *ECOC*

2016 Postdeadline Papers, 2016.



Shigeru Tomita received a B.S. degree in Electronics Engineering from Nihon University in 1983. He joined NTT in 1983 where he engaged in the development of optical fiber cables for access networks. He received a Ph.D degree from Nihon University in 1997. He is now with NTT Advanced Technology Corporation.