

Broadband Optical Access Technologies to Converge towards a Broadband Society in Europe

Jean-Pierre COUDREUSE[†], Sophie PAUTONNIER[‡], Eric LAVILLONNIÈRE[‡], Sylvain DIDIERJEAN^{††}, Benoît HILT^{†††}, Toshimichi KIDA^{††††}, *Nonmembers, and Kazuyoshi OSHIMA^{†a)}, Member*

SUMMARY This paper provides insights on the status of broadband optical access market and technologies in Europe and on the expected trends for the next generation optical access networks. The final target for most operators, cities or any other player is of course FTTH (Fibre To The Home) deployment although we can expect intermediate steps with copper or wireless technologies. Among the two candidate architectures for FTTH, PON (Passive Optical Network) is by far the most attractive and cost effective solution. We also demonstrate that Ethernet based optical access network is very adequate to all-IP networks without any incidence on the level of quality of service. Finally, we provide feedback from a FTTH pilot network in Colmar (France) based on Gigabit Ethernet PON technology. The interest of this pilot lies on the level of functionality required for broadband optical access networks but also on the development of new home network configurations.

key words: FTTH, PON, point to multi point access, broadband access networks, European business models

1. Introduction

The requirement for bandwidth has been continuously increasing during the last decade. It is estimated that the need for bandwidth increases by a factor of 1.3 each year, mainly due to the introduction of new services like interactive games, high definition TV and development of peer to peer applications. Because of the new behaviour of the broadband customers, the available bandwidth is of course an issue but the major expectation for these next generation broadband networks is to provide fair and symmetrical bandwidth allocation schemes.

Access networks can be classified into three main categories: copper, wireless and optical. While some interesting improvements in copper and wireless access technologies now makes it possible to offer customer symmetrical bandwidth up to several tens of Mbit/s, fibre remains by far the most promising technology as it is sustainable with no theoretical limit for bandwidth usage.

While FTTH (Fibre To The Home) had a significant

Manuscript received November 26, 2007.

Manuscript revised March 13, 2008.

[†]The authors are with Mitsubishi Electric Information Technology Centre Europe B.V. (ITE), 1 allée de Beaulieu, CS 10806, 35708 Rennes Cedex 7, France.

^{††}The author is with Vialis, 10 rue des Bonnes Gens, BP 70187, 68004 Colmar Cedex, France.

^{†††}The author is with IUT de Colmar, BP 50568, 68008 Colmar Cedex, France.

^{††††}The author is with Communication Networks Centre, Mitsubishi Electric Corporation, Amagasaki-shi, 661-8661 Japan.

a) E-mail: oshima@tcl.ite.mee.com

DOI: 10.1093/ietcom/e91-b.8.2462

growth rate in Asia and more specifically in Japan [1] with a concentration of almost 10 million subscribers [2], the number of subscribers in Europe is lagging behind with only 1.1 million subscribers at the end of June 2007. Although it is an attractive technology, deployment of FTTH networks requires some huge investment to cover the high cost of civil engineering. This cost is higher in Europe compared to Japan as aerial deployment is usually not allowed. For instance, a study on the FTTH investment in France predicted that 10 billion euros would be basically necessary to cover 40% of the French population [3], and 70% of this cost dedicated to civil engineering. This situation is similar in all over Europe. Therefore, different schemes are considered with not only network operators but also public municipalities who decide to invest in fibre deployment in order to promote early deployment in Europe. In the latter case, fibre cables will be rented to network operators to provide network services to customers.

This paper presents the recent market trends related to FTTH in Europe and describes several optical access technologies which provide broadband capability with 1Gigabit/sec transmission rate. This paper also presents recent results of the pilot project launched in Colmar (France) at the beginning of 2007 using Gigabit Ethernet PON system. This pilot is a collaborative project between Vialis, the representative operator in Colmar, the MIPS/GRTC (Modélisation Intelligence Processing Systemes and Groupe de recherche en Réseaux et Telecoms de Colmar) network research department of the University Institute of Technology of UHA (University of Haute Alsace) in Colmar and Mitsubishi Electric Corporation. We will conclude this paper by providing some insights into the future generations of PON networks.

2. Recent Aspects on FTTH Market in Europe

The need for a quick upgrade from current xDSL networks to FTTH varies with the quality of existing networks (length of local loop, quality of the copper wire) and one of possible solutions is the combination of fibre and VDSL. The discussion on the unbundling regulation policy on optical fibre is still not finalised and will affect the configuration of FTTH networks and the deployment progress.

Nevertheless, FTTH is considered as a key factor for the development of a given geographical area and it can drastically speed-up the economic and social development.

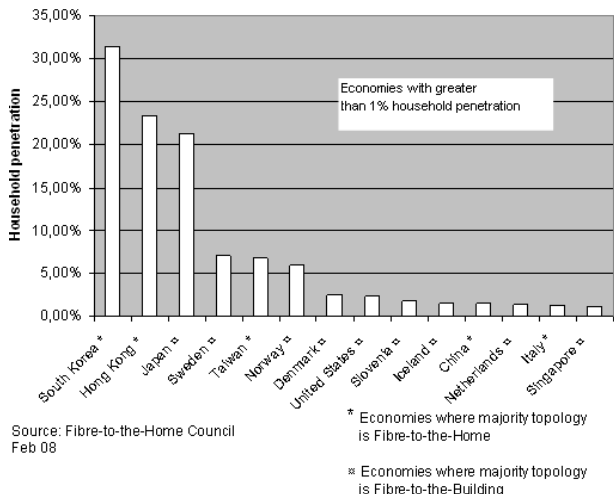

Fig. 1 Global status of FTTH penetration worldwide.

This explains why FTTH is not only concerned by network operators but also by different levels of authorities such as governments or local municipalities. In mid-2006, more than 80% of the FTTH projects in Europe were initiated by municipalities, local power utilities or housing companies.

In February 2008, the three FTTH Council organisations (Europe, Asia-Pacific and North America) published the status of the countries with the highest Fibre-To-The-Home penetration rates worldwide [4], as shown in Fig. 1. Although Asia is leading the race to the fibre, it is interesting to note that since the last ranking in July 2007, new European countries have penetration rate higher than 1%, like Slovenia and Iceland, due to incentive policies. Also, we can notice most European countries present in this ranking deploy FTTH, while FTTB is still widely deployed in Asia.

This new report is an encouraging sign that Europe is at the edge of massive Fibre-To-The Home deployments with exponential growth [5]. It is particularly interesting to notice, several incumbent operators, like in France, Spain, UK, announced in 2007 that they will make important investments to upgrade smoothly their network from ADSL/ADSL2+ to FTTH. In Germany, although the final target is FTTH, the incumbent operator decided to first deploy FTTC/FTTN as described in 3.1. The report from the FTTH Councils only considers FTTH and FTTB deployments and thus do not consider FTTC/FTTN subscribers.

A brief overview of different types of FTTH deployments all over Europe is shown as following:

- In Sweden, the European country with the highest penetration rate, several “citynets” have been deployed. The main drivers are i) the upgrade of the city-owned networks, ii) the expansion to the SME (Small and Medium Enterprise) and other business entities, iii) the possibility to offer broadband services to their citizens. Most of these city networks are operated independently, for instance by a local power utility, and are not connected one to each other. Utilities will be a key player in Europe as they already have their own network infrastructure, although not

telecom operator. Depending on technical and economical constraints, different degrees of openness are achieved [6].

- Nuenen, a small town in Netherlands is one particular example where the citizens have created a cooperative that operate an open network. Any customer is then free to select its favourite ISP. The network connects all the public building (schools, hospitals, churches, etc.).
- In some other countries like Norway or France, alternative operators have ambitious FTTH development strategy.
- In some low density areas, public funding will be a key success factor to deploy broadband networks. Asturias, a rural region in Spain is one typical example where the project has been supported at European level with associated funding.

In Europe, almost all the FTTH networks initiated or supported by local authorities have a strong requirement for open networks. It is very important to maintain fair competitiveness between the different broadband services providers. The different solutions to provide open networks are further described in Sects. 4.2 and 4.4.

The FTTH market in Europe will be thus considered to converge basically into two major business models as followings:

- Vertical integration model
FTTH networks are deployed by existing or new operators that are responsible for network deployment and also directly propose new services to their customers.
- Horizontal cooperation model
Initiatives come from local authorities or power utilities and so on. They may delegate the deployment of FTTH network to an access network operator. This access network operator then opens its network to any ISP or service provider that would like to address the end-customer. In most cases, the access network operator does not have direct contact with the end-customer. Thus, access network operator is sometimes called as “Operator of operators.”

These two business models are likely to be geographically partitioned. Vertical integration models and competition on infrastructures may happen where deployment will be market-driven for private investors — large cities, business areas. On the other hand, horizontal cooperation models will happen where infrastructure deployment is unlikely to be subject for private sector investment and will need public intervention. For example local authorities will be supporting the equipment with long-term investment, mandating network operation to a local operator, and guaranteeing access to service providers on an equal and fair basis.

The cost for FTTH deployment will be decisive in the roll-out speed in the next coming years. As mentioned above, the civil engineering cost is high due to constraints on underground deployment. The population density is also an important factor that impacts the overall cost. For in-

stance, it is estimated that the cost of deployment in UK will be higher compared to France due to a lower density of MDUs (Multi-Dwelling Units). In order to optimise the cost of the deployment, some operators are looking after new solutions that will enable to extend the reach of the optical access networks. One of the solutions currently studied in ITU-T is the specification of some extender box for GPON [7], [8]. One advantage is to simplify the network architecture by decreasing the number of metro nodes leading to reduced operational expenditures [9].

3. FTTH Technologies

3.1 Topologies for Optical Access Networks

Different topologies can be considered for optical access networks. FTTH for Fibre-To-The-Home is the most popular one. However, FTTB for Fibre-To-The-Building is also widely deployed. In this case, copper network is reused for the vertical layout in the building (e.g. VDSL or coaxial cable). Another alternative that can be considered as an intermediate step is the FTTC for Fibre-To-The-Curb also called FTTN for Fibre-To-The-Node. In this particular case, the optical fibre will be typically terminated in a street cabinet, the data then being sent over a VDSL network. Last but not least, the most challenging topology for the next generation access network is the FTTH for Fibre-To-The-Desk. This topology implies a fibre layout inside the apartments or the offices.

Different architectures will co-exist depending on the migration scenario selected by one operator to move to FTTH.

If every operator acknowledges that fibre is the ineluctable physical support for next generation access networks, migration scenario differ from one operator to the other. It depends essentially on the existing physical infrastructure and the level of services that can be offered over the existing network.

For instance, an operator can decide to have an intermediate step before FTTH with FTTC or FTTN technology. In this case, the fibre will be deployed up to the street cabinet and then reuse the copper infrastructure for the drop section with VDSL or VDSL2 technology [10]. VDSL2 enables bit rates up to 100 Mbit/s within a range of few hundreds of meters. This scenario is possible like in Germany in case the average length of the local loop is pretty short. This intermediate step may enable a larger scale of investments than direct FTTH scenario for the time being. However, this required a careful design in case of ADSL lines being operated on the same local loop in order to avoid mutual transmission distortions [10].

In other case the length of local loop is relatively longer, it is difficult to offer high bit rate services over the copper network, and so FTTH scenario is much more preferable. Offering FTTH services to subscribers makes it a real differentiating factor in the latter case. In countries with longer local loop like in France, FTTB and FTTH are the

viable solutions that are considered.

3.2 FTTH Architectures

Hereafter, the two main network architectures envisaged for FTTH deployment are presented. FTTH networks can be deployed with a point to point architecture, meaning one dedicated fibre between the central office and the customers in the fibre plant.

FTTH networks can also be based on PON (Passive Optical Networks). This architecture enables fibre sharing between several subscribers. This is done by using a single fibre from the central office to a splitting point also called flexibility point. Some power splitters are placed in this flexibility point from which, one dedicated fibre is brought to each individual subscriber.

There are several major drawbacks for point to point networks. It first severely impacts the cost of deployment of the fibre plant by increasing drastically the number of fibre to be deployed with its associated civil engineering costs. Furthermore, operational expenditure is increased because of the large number of fibres that need to be connected in the central office.

The risk of failure is also increased with the number of optical termination points, some active components with associated risk of failure. Another drawback is the need for larger central offices and larger power consumption (active equipment and air conditioning). For all the above reasons, this paper will focus on PON solutions in the following descriptions.

Two main gigabit PON systems are currently defined in the standardization bodies [11].

Gigabit Ethernet PON, also called GE-PON or EPON, has been standardised in a specific task force at IEEE to enable point to multipoint Ethernet over fibre. The output of this task force resulted in the ratification of the IEEE 802.3ah [12] standard in June 2004.

Gigabit capable PON, also called G-PON, was defined in the Full Service Access Network (FSAN) consortium and then ratified by ITU (International Telecommunication Union) resulting in different specifications [13]–[16]:

The overall PON physical network architecture is represented in Fig. 2. Most of the operators have upgraded their network to all-IP based networks and all the services can now be delivered over IP networks while ensuring a good QoS (Quality of Service). This is typically the case for voice over IP and video over IP. Ethernet based access networks fit particularly well these new network configurations. We will demonstrate that IP/Ethernet based networks, with a particular focus on EPON are able to provide high quality services with the implementation of specific QoS policies [17].

4. Experiences from the FTTH Pilot in Europe

Vialis, UHA and Mitsubishi Electric have been collaborating for the FTTH pilot project utilising Gigabit EPON system in Colmar, France, from January 2007.

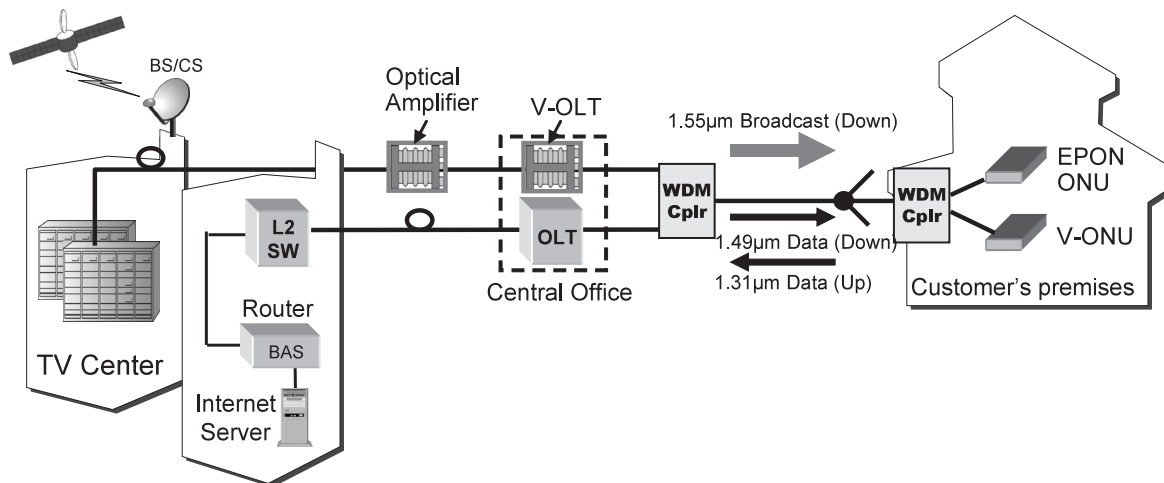

Fig. 2 PON system configuration with RF broadcasting.

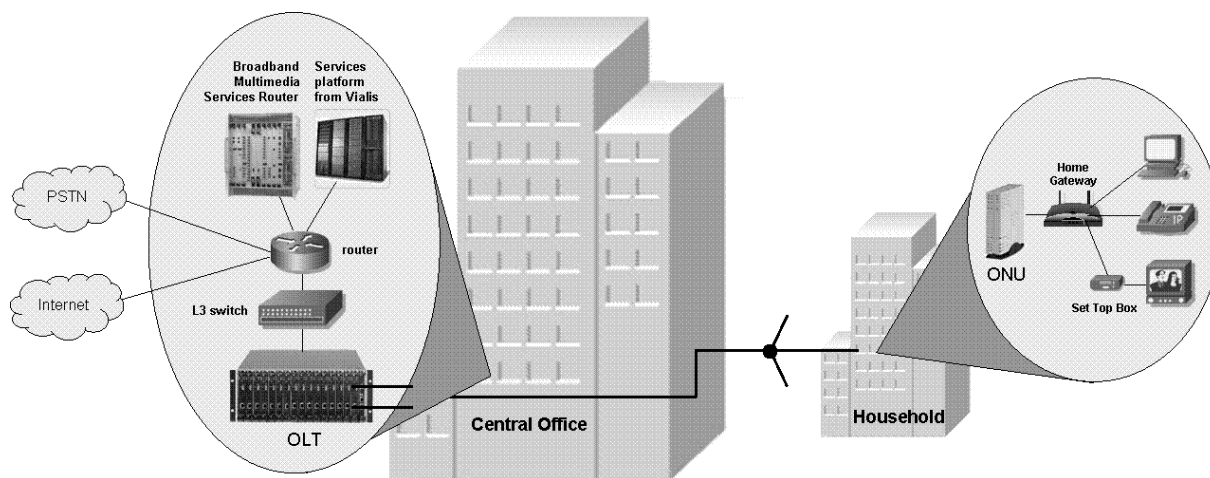

Fig. 3 Network configuration of the Gigabit EPON pilot in Colmar.

Vialis is a local power utility established in Colmar who first provided gas and electricity and are also in charge of public lighting in more than 50 cities around Colmar. Since 1994, they started CATV and ISP services and deployed its telecommunication infrastructure over 5 cities including Colmar. Vialis has partnerships with other power utilities in Alsace and Eastern regions of France.

Vialis also has a strong relationship and collaborative projects with University of Haute Alsace (UHA), particularly the Network and Telecommunication research group (MIPS/GRTC) of the University Institute of Technology in Colmar. The University is usually in charge of evaluating new technologies, new network topologies, QoS management, service provisioning, etc.

4.1 Scope of the FTTH Pilot

The network configuration of Pilot including FTTH access network and residential network is described in Fig. 3.

The OLT is connected on the network side to a 24 port

L3 switch, this switch being connected through a router to the services platform of the operator, Internet and PSTN (Public Switched Telephone Networks), but also video diffusion equipment (Linux video server and broadband multimedia services router). A second EPON network has also been deployed within the University for experimental and evaluation purposes. This platform that implements an equivalent configuration as the one being installed at the customer premises enables the test of new features (VLAN management methods, authentication methods, multicast) and evaluation of different QoS policies.

In a second phase of the pilot, several enterprises have been connected to the Gigabit EPON access network.

This pilot is one of the first FTTH operating networks using PON system in France, thus bringing a lot of expectations from many operators and local authorities in France. From the beginning, it was decided to open this pilot to any visitor potentially interested in this experience. Operators expect feedback on the aspect of business models, while local authorities are mainly interested in the overall deploy-

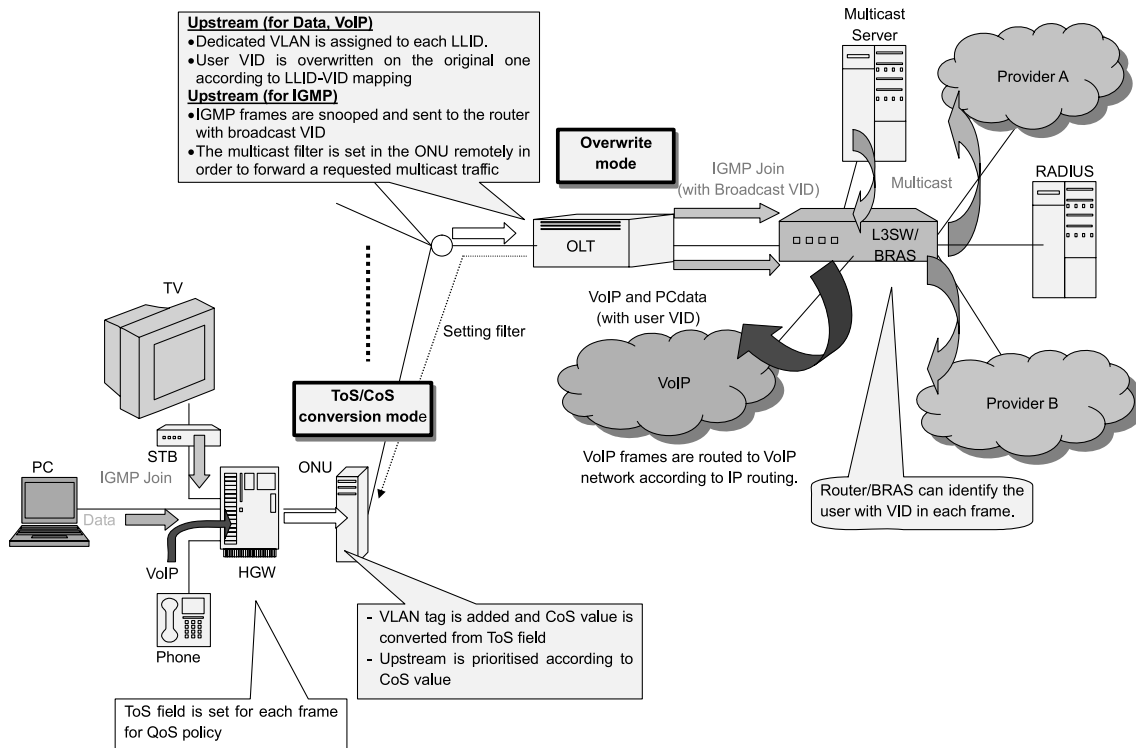

Fig. 4 System overview with management of IGMP traffic in the upstream.

ment process.

4.2 Emergence of New Services

In the initial stage of the pilot, triple play services were provided over FTTH without any particular QoS policy for residential users. Basic triple play services were offered to the end-customer with up to 40 Mbit/s symmetrical bandwidth for each subscriber. Basic triple play services were offered to the end-customer with up to 40 Mbit/s symmetrical bandwidth for each subscriber. However, the configuration has quickly been upgraded by addition of multicast functionality with the support of IGMP (Internet Group Management Protocol) proxy and snooping function in the OLT and in the ONUs. IGMP support is considered as a key feature in optical access networks. It improves indeed the transmission efficiency by eliminating the necessary bandwidth at UNI for multicast flows requested by other users connected to the same PON interface in the OLT. Indeed, OLT acts as an IGMP proxy and ONU integrates filtering.

Figure 4 represents a system overview of the whole system and explains how to manage the unicast and multicast flows with associated VLAN mapping. In this example, ONU is connected to a HGW acting as the termination point of the home network. Unicast traffic is carried over a dedicated VLAN. Different VLAN management policies are possible. The most interesting ones are transparent mode, i.e. no specific action is done from the incoming or outgoing frames, and ToSCoS mode. In the latter case, ONU translates the priority field from the incoming packet (IPv4 ToS

field or IPv6 traffic class field) into a VLAN tag (CoS). The data can then be allocated to a related queue associated with this service priority as explained in Sect. 4.3. This results in better quality of service as service differentiation is done on a priority level, although data are carried over a unique VLAN identifier. Multicast traffic is carried over the broadcast VID. OLT can send the multicast traffic either based on VID filtering mode or MAC-DA (MAC Destination Address) mode.

It is also important to highlight another function of the VLAN. Indeed, they also enable active unbundling of the networks by allocating specific VLAN identifiers to a given service provider.

Considering the enterprise applications, pilot customers have been immediately enthusiastic. They quickly innovated to provide more advanced services, but also drastically improve their internal information system. As an example, because of the high bandwidth available in the upstream, the servers of the customer companies can support multiple and simultaneous accesses from remote terminals without any congestion effect. This feature is therefore highly appreciated as it avoids remote terminal users to store confidential data on their own computers.

Concerning the allocated bandwidth, it has been observed very quickly after the start of the experience that the subscribers have been largely using the available bandwidth in the upstream, leading very often to larger upstream traffic than downstream traffic. This can be explained with the profile of the subscribers. In this experience, a high percentage of the residential users are students and are widely con-

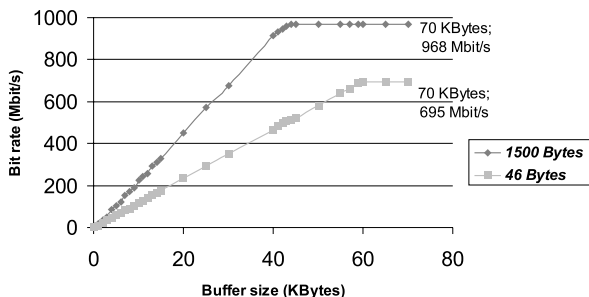

Fig. 5 Maximum bandwidth vs. queue size in the upstream.

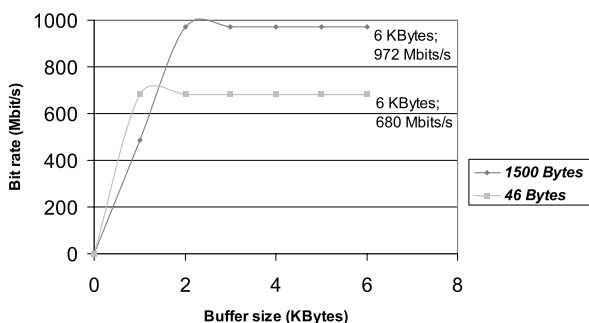

Fig. 6 Maximum bandwidth vs. queue size in the downstream.

nected to peer-to-peer networks. It has been demonstrated that our society is now moving from a providers contents delivery to a user-generated contents exchange. This will have strong impact on the dimensioning of the overall network including the core, but also on the dimensioning of CPU processing required for the servers.

4.3 Quality of Service for Service Differentiation

A major condition to reach an adequate quality of service is to have specific processing for the services depending on their priorities. Typically, voice service has much higher priority than file transfer, because of its strong real-time constraints.

In order to solve this issue, four queues are possibly configured in each ONU, each one with a different priority, both for upstream and downstream. The size of each queue can be configured by the operator in order to optimise the overall quality of services depending on its own package of services.

In order to check the impact of the size of the queue on the available bandwidth, we measured the bandwidth both in upstream and downstream for different length of queue, as illustrated in Fig. 5 and Fig. 6. The evaluation has been performed for 1500-byte packets' payload and for 46-byte packets' payload. The measured bandwidth is with the payload data of packet excluding the PON-header and Ethernet-header parts.

In case of short packets, usually the case for high priority traffic like voice or video, the evaluation demonstrated that a size of 60 kbytes for the upstream and 1 kbytes for the



Fig. 7 Optical connection box for the pilot.

downstream are sufficient to reach an optimum bandwidth utilisation.

In case of long packets, usually the case for low priority traffic like web browsing, file transfer, the evaluation demonstrated that a size of 45 kbytes for the upstream and 2 kbytes for the downstream are sufficient to reach an optimum bandwidth utilisation.

4.4 Multiple Operators Configuration

As discussed previously, different business models are foreseen for FTTH networks, with both vertical and horizontal models. The pilot demonstrated that it was even possible to have a co-existence of both business models. By upgrading current subscribers from CATV services to FTTH services, the vertical model would be applied as network deployment, network operation and providing services are managed by a single entity. Besides, horizontal model is also possible by providing a FTTH access pipe to other ISPs. This "pipe" could consist in providing open access to the optical plant (passive unbundling) or bandwidth to the other ISPs (active unbundling or "bit-stream scheme").

To anticipate configurations with multiple operators, Vialis has tested during the pilot passive equipment enabling several operators to access the flexibility point. Figure 7 shows the optical connection box for the pilot.

4.5 Home Network Configuration

Another key aspect of the pilot is the evaluation of different home network configurations in order to select the most appropriate one. This point is very important for the majority of European operators. The question is how to offer a wide range of services without leading to a messy configuration where each application would require a specific box (with all its associated cables).

A technology that is widely used for home network is based on wireless Ethernet technology (802.11 a/b/g). Most of the ISPs in France provide their own home gateway including Wi-Fi interface. However, wireless home network

can not be the universal solution because of some limitation factors like range, signal penetration in some particular buildings, human sensitivity to radio signals, etc. To overcome these issues, Power Line Communications (PLC) recently emerged. It appears as a reliable solution providing high bit rate access. Of course, traditional wired Ethernet networks over category 5 or category 6 cables remains the solution that provides the fastest data transmission rate, with a reliable and standard-based solution.

Considering home network evolution, special care needs to be provided on TV distribution. With FTTH networks, IPTV becomes feasible even in the case of a large number of channels to be broadcasted. Thus, the need for multicast support is really important. However, the migration scenario is still under discussions. Indeed, IPTV requires the introduction of a set top box in charge of decoding the received video flow, introducing an additional box with its associated cost while the existing cable infrastructure already enables efficient TV distribution inside the customer premises. The issue is that the existing network assumes analogue video distribution. Cable operators may decide on a case by case basis, to maintain this existing network and will therefore use the capability offered by the PON networks to send broadcast RF video over the third wavelength as described in Fig. 2.

5. Discussion on Future Technologies for Broadband Optical Access Network

In this paper, we have studied that PON architectures have many benefits compared to point to point architecture. Moreover, we can see that PON is a sustainable solution for the longer term investment. Future generations of PON are now being envisaged.

First, 10G-PON based on two-wavelength TDM system is being standardised in FSAN and in IEEE. For use in 10G-PON system, the optical interface technologies have been developed and demonstrated that power budgets and dispersion penalties equivalent to Gigabit EPON or GPON are practical [18].

In a later stage, WDM-PON will be proposed enabling point to point logical links between the central office and the users. For WDM-PON systems, one of the basic device technologies has already been developed with ONU-specific SOA (Semiconductor Optical Amplifier)—EA (Electro-Absorption) modulator—SOA integrated device and it could give favourable optical waveforms and transmission characteristics [18]. The most important challenge for the next coming years is the cost of the optical devices that need to be drastically decreased so that they can be used in mass market products.

6. Conclusions

Through this paper, we have described recent aspect on FTTH market in Europe and analysed the different broadband access network architectures that are now emerging.

Because there is a general trend to move to all-IP networks, we discussed that Ethernet based access networks is the most adequate solution. We also demonstrated that PON architectures have many benefits compared to point to point architectures. As illustrated in the pilot in Colmar, Gigabit Ethernet PON, which was developed at first in Japan, is proven to be an adequate technology in order to converge towards a broadband society in Europe. Although not discussed in this paper, we would like to emphasise the benefits of FTTH on the sustainable development by enabling teleworking, e-health and care, assistance to elderly dependent people. The impact of FTTH on sustainable development is also studied steadily in Europe.

Acknowledgements

The authors would like to thank Jacky Hahn, head of technical department in Vialis and Mounir Sarni, Ph.D. student at the MIPS/GRTC lab of the University of Haute Alsace in Colmar for their precious collaboration in the deployment and operation of EPON pilot in Colmar, France.

References

- [1] H. Shinohara, "FTTH experiences in Japan," *J. Optical Networking*, vol.6, no.6, pp.616–623, June 2007.
- [2] K. Sato, "Telecommunications market in Japan and NTT's strategy for FTTH," *DigiWorld Summit 2007*, 2007.
- [3] R. Montagne, "Who should pay for FTTH?," *DigiWorld Summit 2007*, 2007.
- [4] FTTH Council, "<http://www.ftthcouncil.eu>," Feb. 2008.
- [5] B. Felten and O. Jerphagnon, "An overview of fiber," <http://www.citynet.nl/upload/FttX-in-Europe-29june2007.pdf>, Nov. 2007.
- [6] C.P. Larsen, "Access network technologies: Deployments in Sweden," *ECOC*, Sept. 2007.
- [7] ITU-T G.984.re, SG15, "G-PON optical reach extension," Jan. 2008.
- [8] K. Suzuki, Y. Fukada, D. Nettet, and R. Davey, "Amplified gigabit PON systems," *J. Optical Networking*, vol.6, no.5, pp.422–433, May 2007.
- [9] R.P. Davey, D.B. Payne, D. Nettet, P. Tomlinson, T. Gilfedder, P. Chidgey, and A. Rafel, "Long-reach access and future broadband network," *ECOC*, Sept. 2007.
- [10] N. Gieschen, "FTTC: The concept for implementing broadband access and the experience of Deutsche telekom," *ECOC*, Sept. 2007.
- [11] F. Effenberger, D. Cleary, O. Haran, G. Kramer, R. Ding Li, M. Oron, and T. Pfeiffer, "An introduction to PON technologies," *IEEE Commun. Mag.*, vol.45, no.3, pp.S17–S25, March 2007.
- [12] IEEE 802.3ah, "Ethernet in the first mile," June 2004.
- [13] ITU-T G.984.1, SG15, "Gigabit-capable passive optical networks (G-PON): General characteristics," March 2003.
- [14] ITU-T G.984.2, SG15, "Gigabit-capable passive optical networks (G-PON): Physical media dependent (PMD) layer specification," March 2003.
- [15] ITU-T G.984.3, SG15, "Gigabit-capable passive optical networks (G-PON): Transmission convergence layer specification," July 2005.
- [16] ITU-T G.984.4, SG15, "Gigabit-capable passive optical networks (G-PON): ONT management and control interface specification," June 2005.
- [17] M. Takemoto and H. Yamanaka, "Technologies for gigabit EPON systems," *Mitsubishi Electric Advance*, vol.114, pp.8–10, June 2006.
- [18] J. Nakagawa and K. Shimizu, "Next-generation optical access systems," *Mitsubishi Electric Advance*, vol.114, pp.23–25, June 2006.



Jean-Pierre Coudreuse was graduated from Ecole Polytechnique in 1966 and from Ecole Nationale Supérieure des Télécommunications in 1971. He was nominated as Ingénieur Général des Télécommunications in 1996 after 25 years working for France Telecom R&D centre (CNET). He joined Mitsubishi Electric Corporation ITE (Telecommunications research laboratory) in 1996, to start and develop as a general manager this laboratory dedicated to wireless and wired emerging

technologies. Before that, Jean-Pierre Coudreuse has been working for France Telecom R&D on digital telecom networks and technologies, accompanying for 25 years the telecom digital revolution. He contributed to broadband ISDN and ATM technology design and standardisation. He submitted the first contribution on ATM to the ITU-T in 1986, further contributing to standardisation of that technology until 1996, as a French representative with the status of International expert as an ITU-T SG 13 Special Rapporteur. In 2002, Jean-Pierre Coudreuse was appointed as a member of the French Academy of Technologies.



Benoît Hilt is assistant professor at the MIPS laboratory of the University of Haute Alsace at Colmar in France. His research interests are focused on architectures and management of multicast communications. The possibility to benefit from the FTTH PON system enables him to conduct a pragmatic approach of his research interest, notably in high speed multicasting.



Toshimichi Kida is a manager in Optical Access Networks Department of Mitsubishi Electric Corporation's Communication Networks Center. He received a B.S degree in material science from Osaka University, Japan in 1987 and an M.S.E. degree in Electrical Engineering from Princeton University in 1999. He has been working on the development for FTTH systems including B-PON and Gigabit Ethernet PON (GE-PON).



Sophie Pautonnier joined Mitsubishi Electric Corporation ITE in May 1997. She is now technical and business support manager for FTTH systems and has been contributing to several lobbying groups for FTTH development in France and in Europe. She is also involved in R&D projects for the next generation PON technologies. Prior to FTTH, she was involved in mobile network access networks (standardisation, business development). She holds an engineering degree in Electronics from Poly-

tech' Nantes (France).



Kazuyoshi Oshima received the B.S. degree from Nagoya Institute of Technology in 1973, the M.S. and the Ph.D. degrees from the University of Tokyo, in 1975 and 1978, respectively, all in electronics engineering. Since 1978, he has been with Mitsubishi Electric Corporation. He was involved in the research and development of optical fibre transmission system and digital multiplexing equipment. From 1987 to 1988, he was a visiting researcher in University of California, Los Angeles. From 1989, he has been

engaged in the research and development of ATM network technologies optical access networks, Ethernet based PON system and photonic network system. From October 2004, he has been serving as President of Mitsubishi Electric ITE (Information Technology Centre Europe), located in Rennes France and in Guildford UK, and pursuing advanced communication technologies and visual information technologies. Dr. Oshima is a member of the Institute of Image Information and Television Engineer of Japan and the IEEE.



Eric Lavillonnière was graduated from Ecole des Mines de Nancy in 1984. He started as a software engineer for Sema Group, where he worked on software engineering tools. In Sema Group Telecom subsidiary from 1994, he focused on telecom software particularly Network Management System. He joined Mitsubishi ITE in October 2000. After working on 3G system simulation and optimisation, he now studies current and future PON systems.



Sylvain Didierjean was graduated from Ecole Supérieure d'Electricité in 1994. He joined Vialis in 1995 as an R&D engineer in charge of the metropolitan ATM network deployment. In 1998, he led the technical department of the telecommunication division and developed fibre networks to connect some enterprises. Since 2003, he is the general manager of the telecommunication division, for cable TV, Internet and telephony, and is working in partnership with other local operators to provide services to their own customers. He supervised the migration from traditional POTS services to VoIP services and is also investigating the appropriate strategy to develop FTTH network for residential users. Since 2004, he chairs ANROC's (French association of cable operators) committee for electronic communications.