

IEICE **TRANSACTIONS**

on Communications

DOI:10.1587/transcom.2017CQI0001

Publicized:2018/01/22

This advance publication article will be replaced by the finalized version after proofreading.

A PUBLICATION OF THE COMMUNICATIONS SOCIETY



The Institute of Electronics, Information and Communication Engineers
Kikai-Shinko-Kaikan Bldg., 5-8, Shibakoen 3chome, Minato-ku, TOKYO, 105-0011 JAPAN

Effect of User Antenna Selection on Block Beamforming Algorithms for Suppressing Inter-user Interference in Multiuser MIMO System

Nobuyoshi KIKUMA[†], *Fellow*, Kentaro NISHIMORI^{††}, and Takefumi HIRAGURI^{†††}, *Senior Members*

SUMMARY Multi-user MIMO (MU-MIMO) improves the system channel capacity by generating a large virtual MIMO channel between a base station and multiple user terminals (UTs) with effective utilization of wireless resources. Block beamforming algorithms such as Block Diagonalization (BD) and Block Maximum Signal-to-Noise ratio (BMSN) have been proposed in order to realize MU-MIMO broadcast transmission. The BD algorithm cancels inter-user interference (IUI) by creating the weights so that the channel matrices for the other users are set to be zero matrices. The BMSN algorithm has a function of maintaining a high gain response for each desired user in addition to IUI cancellation. Therefore, the BMSN algorithm generally outperforms the BD algorithm. However, when the number of transmit antennas is equal to the total number of receive antennas, the transmission rate by both BD and BMSN algorithms is decreased. This is because the eigenvalues of channel matrices are too small to support data transmission. To resolve the issue, this paper focuses on an antenna selection (AS) method at the UTs. The AS method reduces the number of pattern nulls for the other users except an intended user in the BD and BMSN algorithms. It is verified via bit error rate (BER) evaluation that the AS method is effective in the BD and BMSN algorithms, especially, when the number of user antennas with a low bit rate (i.e., low signal-to-noise power ratio) is increased. Moreover, this paper evaluates the achievable bit rate and throughput including an actual channel state information feedback based on IEEE802.11ac standard. Although the number of equivalent receive antenna is reduced to only one by the AS method when the number of antennas at the UT is two, it is shown that the throughputs by BD and BMSN with the AS method (BD-AS and BMSN-AS) are higher than those by the conventional BD and BMSN algorithms.

key words: *Multiuser MIMO, Block beamforming, User antenna selection, Achievable bit rate, Throughput.*

1. Introduction

We can feel and enjoy the explosive expansion of cellular networks and wireless LANs (WLANs) along with the growing popularity of smart phones and tablets. At the same time, it has presented the demand for achieving broadband wireless transmission within a limited frequency band. In the past fifteen years, the most effective and most attractive technology for a high transmission rate is multiple-input multiple-output (MIMO) transmission [1]–[7]. MIMO promises to increase the channel capacity compared to single-input single-output

(SISO) systems. Therefore, MIMO has been incorporated into many of the latest wireless communication standards such as Long-Term Evolution (LTE) [8], WiFi [9], and WiMAX [10]. Moreover, multi-user MIMO (MU-MIMO) systems have recently attracted even more attention as a technology that enhances the total system capacity. It is because it can generate a large virtual MIMO channel between a base station and multiple user terminals (UTs) with effective utilization of wireless resources [11]–[14].

MU-MIMO transmission realizes communication with multiple terminal stations with a limited number of antennas called space division multiple access (SDMA) [15]–[17]. Actually, MU-MIMO transmission has been incorporated into the IEEE802.11ac standard [18] and LTE-Advanced standard [19], and so commercial products based on these standards will appear in the near future. The standardization of next-generation WLAN also aims to achieve further high performance and high efficiency by using MU-MIMO transmission technology. From this technological background, MIMO/MU-MIMO transmissions are key technologies for the next-generation mobile radio network and WLAN systems.

Block Diagonalization (BD) is well known as one of pre-coding algorithms with moderate complexity in MU-MIMO broadcast channel [20]. The BD algorithm creates the transmit weights so as to ensure zero inter-user and inter-stream interference in the received signals of each user. In addition, Block Maximum Signal-to-Noise ratio (BMSN) algorithm has been proposed as a modified method of BD algorithm [21]. The BMSN algorithm aims at achieving positive block beamforming for each user as well as reducing inter-user interference (IUI). However, when the number of transmit antennas is equal to the total number of receive antennas, the transmission rate by the BD and BMSN algorithms is decreased [21], [22].

One of the methods to improve the performance of BD and BMSN algorithms is the combination with user selection algorithm that comes close to the sum capacity achieved by Dirty Paper Coding (DPC) [23], [24]. Generally speaking, a lot of information regarding channel state information (CSI) is necessary for the user scheduling algorithm [25], [26]. Another way to improve the performance of MU-MIMO broadcast channel is to use non-linear pre-coding method [27]–[29]. Furthermore, the BD with vector perturbation (VP) is proposed in order to enhance the performance of BD algorithm [30]. However, calculation complexity becomes very huge by the use of VP, because the optimal

[†]The author is with Faculty of Engineering, Nagoya Institute of Technology, Gokiso-cho, Showa-ku, Nagoya-shi, Aichi 466-8555 Japan.

^{††}The author is with Faculty of Engineering, Niigata University, Niigata-shi, Niigata 950-2102 Japan.

^{†††}The author is with Faculty of Engineering, Nippon Institute of Technology, 4-1 Gakuendai, Miyashiro-machi, Minamisaitamagun, Saitama 345-8501 Japan.

perturbation in each symbol is required by this method.

In this paper, we focus on a simple antenna selection (AS) method at the UT to reduce the number of pattern nulls for inter-user interference (IUI) cancellation in the BD and BMSN algorithms [31]. In the AS method, the user antennas which are used in the BD and BMSN algorithms are selected by just the signal-to-noise power ratio (SNR) at each UT. The BD and BMSN with the AS method are referred to as BD-AS and BMSN-AS, respectively. Although several types of the user and antenna selection schemes have been proposed [25], [26], the aim of the AS method is to improve the performance on the BD and BMSN algorithms without user scheduling or non-linear pre-coding.

Methods that reduce the number of pattern nulls for the IUI in the BD algorithm are already proposed in [32] and [33]. Because the former method reduces the number of pattern nulls by the antenna selection at the UT, the basic idea in [32] is the same as that in the AS method. However, the additional method in [34] is used as the measure on the antenna selection in [32]. Consequently, the AS method realizes the simpler antenna selection than the method in [32].

In contrast, the latter method improves the performance in the BD algorithm not by antenna selection at the UT but by control of the number of data streams and non-orthogonal transmitting weight control [33]. The bit error rate (BER) performance by the method in [33] will be improved to the same or higher degree on the AS method. However, the method in [33] requires the minimum mean square error (MMSE) processing at each UT. Hence, the burden on the signal processing part is increased as the number of antennas at the UT is increased. On the other hand, the calculation complexity of the BD-AS and BMSN-AS algorithms is almost the same as that of the conventional BD and BMSN.

Here, we demonstrate via BER and achievable bit rate evaluations that the BD-AS and BMSN-AS algorithms are effective compared to the conventional BD and BMSN [22]. Afterwards, we evaluate the throughput considering the medium access control (MAC) layer based on IEEE802.11ac standard [18]. Through this evaluation, we compare the performance between BD, BMSN, BD-AS and BMSN-AS when the CSI feedback which gives a large overhead in MU-MIMO transmission is considered [35]. Particularly, the BD-AS and BMSN-AS algorithms are expected to be effective in the low SNR because the smallest eigenvalues of channel matrix cannot be used in the conventional BD and BMSN even if the user scheduling is used on actual modulation schemes. Moreover, from a point of view on the amount of CSI feedback, the AS method is supposed to produce the enhanced performance, because the number of data streams is reduced but nevertheless the SNR of data stream for each user by BD-AS and BMSN-AS is much higher than that by the conventional BD and BMSN.

This paper is organized as follows. In Sect. 2, we begin with the system model and explain linear transmission control algorithms including Zero Forcing (ZF), BD, and BMSN, followed by their common issue. To address the

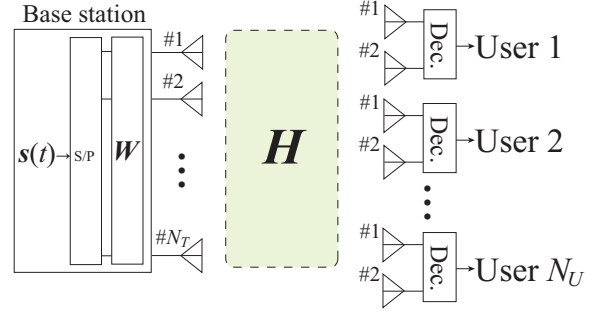

Fig. 1 System model of MU-MIMO broadcast channel ($N_R = 2$).

issue, we introduce the AS method for UT into the BD and BMSN in Sect. 3. In Sect. 4, the BER performance and the achievable bit rate are evaluated for the algorithms presented here. Subsequently, their throughput characteristics considering the medium access control (MAC) layer are examined. The discussion about the effect of user antenna selection on BD and BMSN and the perspective of those algorithms are provided in Sect. 5. Finally, the concluding remarks are presented in Sect. 6.

2. Linear Transmission Control Algorithms in MU-MIMO Broadcast Channel

2.1 System Model

In this paper, we focus on the linear transmission control because of its low complexity of computation. Figure 1 shows the system model for MU-MIMO broadcast channel. The numbers of transmit antennas, receive antennas, and users are N_T , N_R , and N_U , respectively, and the case where $N_R = 2$ is depicted in Fig. 1. The total channel matrix is $\mathbf{H} \in \mathbb{C}^{N_R \cdot N_U \times N_T}$ composed of individual user channel matrices denoted by $\mathbf{H}^{(k)} \in \mathbb{C}^{N_R \times N_T}$ ($k = 1 \sim N_U$). The transmit signal vector at the t -th symbol is $\mathbf{s}(t) \in \mathbb{C}^{N_T \times 1}$, and it consists of the transmit signal vectors for all users, denoted by $\mathbf{s}^{(k)}(t) \in \mathbb{C}^{N_T \times 1}$ ($k = 1 \sim N_U$). The transmit weight matrix is $\mathbf{W} \in \mathbb{C}^{N_T \times N_R \cdot N_U}$, and similarly it is constructed by $\mathbf{W}^{(k)} \in \mathbb{C}^{N_T \times N_R}$ ($k = 1 \sim N_U$) each of which denotes the weight matrix for user k .

Therefore, we have following relations:

$$\mathbf{H} = \begin{bmatrix} \mathbf{H}^{(1)} \\ \vdots \\ \mathbf{H}^{(N_U)} \end{bmatrix}, \quad (1)$$

$$\mathbf{W} = [\mathbf{W}^{(1)}, \dots, \mathbf{W}^{(N_U)}], \quad (2)$$

and

$$\mathbf{s}(t) = \left[\left(\mathbf{s}^{(1)}(t) \right)^T, \dots, \left(\mathbf{s}^{(N_U)}(t) \right)^T \right]^T. \quad (3)$$

At the receiver side, the receive signal of user k at the t -th symbol is denoted by $\mathbf{y}^{(k)}(t) \in \mathbb{C}^{N_R \times 1}$ ($k = 1 \sim N_U$), and

so the receive signal vector for all users, $\mathbf{y}(t) \in \mathbb{C}^{N_R \cdot N_U \times 1}$, is given by

$$\mathbf{y}(t) = \left[\left(\mathbf{y}^{(1)}(t) \right)^T, \dots, \left(\mathbf{y}^{(N_U)}(t) \right)^T \right]^T. \quad (4)$$

As a result, the receive signals $\mathbf{y}^{(k)}(t)$ and $\mathbf{y}(t)$ are expressed as follows:

$$\mathbf{y}^{(k)}(t) = \mathbf{H}^{(k)} \mathbf{W} \mathbf{s}(t) + \mathbf{n}^{(k)}(t) \quad (5)$$

$$\mathbf{y}(t) = \mathbf{H} \mathbf{W} \mathbf{s}(t) + \mathbf{n}(t) \quad (6)$$

$$\mathbf{n}(t) = \left[\left(\mathbf{n}^{(1)}(t) \right)^T, \dots, \left(\mathbf{n}^{(N_U)}(t) \right)^T \right]^T \quad (7)$$

where $\mathbf{n}^{(k)}(t) \in \mathbb{C}^{N_R \times 1}$ denotes the internal noise vector at the receiver of user k . When the receive weight $\mathbf{W}_r^{(k)} \in \mathbb{C}^{N_R \times N_R}$ is used at user k , the receive signal $\mathbf{y}^{(k)}(t)$ of user k can be expressed as follows:

$$\mathbf{y}^{(k)}(t) = \mathbf{W}_r^{(k)} \left(\mathbf{H}^{(k)} \mathbf{W} \mathbf{s}(t) + \mathbf{n}^{(k)}(t) \right). \quad (8)$$

2.2 Zero-Forcing (ZF) Algorithm

When ZF algorithm [36] is employed at the transmitter side, it is also called channel inversion (CI) algorithm. Therefore, when $N_R \cdot N_U = N_T$, the transmit weight of ZF algorithm, \mathbf{W}_{ZF} , is given by

$$\mathbf{W}_{ZF} = \frac{\mathbf{H}^{-1}}{\|\mathbf{H}^{-1}\|_F} \quad (9)$$

where $\|\cdot\|_F$ denotes the Frobenius norm of matrix and $\|\mathbf{H}^{-1}\|_F$ is the normalizing factor for constant transmit power. When $N_R \cdot N_U < N_T$, we obtain the following expression by using pseudo-inverse:

$$\mathbf{W}_{ZF} = \frac{\mathbf{H}^H (\mathbf{H} \mathbf{H}^H)^{-1}}{\|\mathbf{H}^H (\mathbf{H} \mathbf{H}^H)^{-1}\|_F}. \quad (10)$$

If we give a diagonal loading $\beta = \sigma^2 N_U$ (σ^2 : internal noise power) to the matrix $\mathbf{H} \mathbf{H}^H$ in Eq.(10), that is to say, $\mathbf{H} \mathbf{H}^H + \beta \mathbf{I}$ (\mathbf{I} : identity matrix), then the transmit weight is equivalent to that of MMSE (Minimum Mean Square Error) algorithm [28], [37].

Consequently, the receive signal is expressed from Eqs.(6) and (9) as follows:

$$\begin{aligned} \mathbf{y}(t) &= \mathbf{H} \mathbf{W}_{ZF} \mathbf{s}(t) + \mathbf{n}(t) \\ &= \frac{\mathbf{H} \mathbf{H}^{-1}}{\|\mathbf{H}^{-1}\|_F} \mathbf{s}(t) + \mathbf{n}(t) \\ &= \frac{1}{\|\mathbf{H}^{-1}\|_F} \mathbf{s}(t) + \mathbf{n}(t) \end{aligned} \quad (11)$$

As found from the above equation, the separation of substreams of each user as well as user signals is achieved although the received power is degraded by $\frac{1}{\|\mathbf{H}^{-1}\|_F}$.

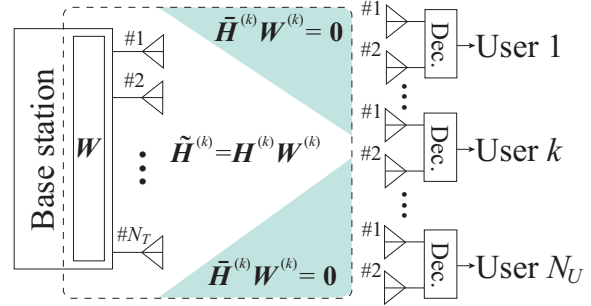

Fig. 2 Spatial channel conditions using transmit weight for user k in BD algorithm ($N_R = 2$).

2.3 Block Diagonalization (BD) Algorithm

In the example of $N_U = 2$, $\mathbf{H}^{(1)} \mathbf{W}^{(1)} \mathbf{s}^{(1)}(t)$ and $\mathbf{H}^{(2)} \mathbf{W}^{(2)} \mathbf{s}^{(2)}(t)$ must be transmitted to user 1 and 2, respectively. On the other hand, $\mathbf{H}^{(1)} \mathbf{W}^{(2)} \mathbf{s}^{(2)}(t)$ and $\mathbf{H}^{(2)} \mathbf{W}^{(1)} \mathbf{s}^{(1)}(t)$ are interferences for user 1 and 2, respectively. Regardless of the transmit signals, the following condition must be satisfied to cancel inter-user interference.

$$\mathbf{H}^{(1)} \mathbf{W}^{(2)} = \mathbf{H}^{(2)} \mathbf{W}^{(1)} = \mathbf{0}_{N_R \times N_R}. \quad (12)$$

In the BD algorithm [20], $\mathbf{W}^{(1)}$ and $\mathbf{W}^{(2)}$ are calculated to meet the condition of Eq.(12).

Here, we explain the BD algorithm with an arbitrary number of users. In order not to transmit signal for all the users except user k ($k = 1 \sim N_U$), we firstly prepare the matrix, $\tilde{\mathbf{H}}^{(k)}$, defined as,

$$\tilde{\mathbf{H}}^{(k)} = \begin{bmatrix} \mathbf{H}^{(1)} \\ \vdots \\ \mathbf{H}^{(k-1)} \\ \mathbf{H}^{(k+1)} \\ \vdots \\ \mathbf{H}^{(N_U)} \end{bmatrix} \in \mathbb{C}^{(N_U-1) \cdot N_R \times N_T} \quad (13)$$

where $\tilde{\mathbf{H}}^{(k)}$ is a channel matrix excluding the channel matrix of user k , $\mathbf{H}^{(k)}$, from \mathbf{H} . Figure 2 represents the spatial channel conditions when the transmit weight for user k is used in the system model of Fig. 1. Next, singular value decomposition (SVD) is applied to the matrix $\tilde{\mathbf{H}}^{(k)}$, resulting in

$$\begin{aligned} \tilde{\mathbf{H}}^{(k)} &= \tilde{\mathbf{U}}^{(k)} \tilde{\mathbf{D}}^{(k)} (\tilde{\mathbf{V}}^{(k)})^H \\ &= \tilde{\mathbf{U}}^{(k)} \begin{bmatrix} \tilde{\mathbf{D}}_s^{(k)} & \mathbf{0}_{N_R \cdot (N_U-1) \times (N_T - N_R \cdot (N_U-1))} \end{bmatrix} \\ &\quad \cdot \begin{bmatrix} \tilde{\mathbf{V}}_s^{(k)} & \tilde{\mathbf{V}}_n^{(k)} \end{bmatrix}^H \end{aligned} \quad (14)$$

where $\tilde{\mathbf{U}}^{(k)}$ and $\tilde{\mathbf{V}}^{(k)}$ are unitary matrices consisting of all right singular vectors and of all left singular vectors, respectively. $\tilde{\mathbf{D}}^{(k)}$ is the diagonal matrix consisting of all singular

values. Also, $\tilde{\mathbf{V}}_s^{(k)}$ and $\tilde{\mathbf{V}}_n^{(k)}$ denote the right singular matrices, which consist of the singular vectors corresponding to nonzero singular values and zero singular values, respectively, and $\tilde{\mathbf{D}}_s^{(k)}$ is the diagonal matrix consisting of nonzero singular values only. To suppress in advance the interferences of all users except user k , we choose the matrix $\tilde{\mathbf{V}}_n^{(k)}$ as the transmit weight for user k , which yields the following relationship between $\tilde{\mathbf{V}}_n^{(k)}$ and $\tilde{\mathbf{H}}^{(k)}$:

$$\begin{aligned} \mathbf{H}^{(1)}\tilde{\mathbf{V}}_n^{(k)} &= \dots = \mathbf{H}^{(k-1)}\tilde{\mathbf{V}}_n^{(k)} = \mathbf{H}^{(k+1)}\tilde{\mathbf{V}}_n^{(k)} = \dots \\ &= \mathbf{H}^{(N_U)}\tilde{\mathbf{V}}_n^{(k)} = \mathbf{0}_{N_R \times (N_T - N_R \cdot (N_U - 1))}. \end{aligned} \quad (15)$$

Hence, user-by-user block diagonalization of channel matrix, i.e., inter-user interference cancellation, can be realized when $\mathbf{W}^{(k)} = \tilde{\mathbf{V}}_n^{(k)}$.

As shown in Fig. 2, the channel matrix $\tilde{\mathbf{H}}^{(k)} = \mathbf{H}^{(k)}\tilde{\mathbf{V}}_n^{(k)}$ is regarded as that of single user MIMO for user k . In the BD algorithm, the eigenmode transmission beamforming (EM-BF) [38], [39] is employed for the matrix $\tilde{\mathbf{H}}^{(k)}$. Namely, applying SVD to $\tilde{\mathbf{H}}^{(k)}$ gives

$$\begin{aligned} \tilde{\mathbf{H}}^{(k)} &= \tilde{\mathbf{U}}^{(k)}\tilde{\mathbf{D}}^{(k)}(\tilde{\mathbf{V}}_n^{(k)})^H \\ &= \tilde{\mathbf{U}}^{(k)} \begin{bmatrix} \tilde{\mathbf{D}}_s^{(k)} & \mathbf{0}_{N_R \times (N_T - N_R \cdot N_U)} \end{bmatrix} \begin{bmatrix} \tilde{\mathbf{V}}_s^{(k)} & \tilde{\mathbf{V}}_n^{(k)} \end{bmatrix}^H \end{aligned} \quad (16)$$

where $\tilde{\mathbf{U}}^{(k)}$ and $\tilde{\mathbf{V}}_n^{(k)}$ are the left singular matrix and the right singular matrix of $\tilde{\mathbf{H}}^{(k)}$, respectively, and $\tilde{\mathbf{D}}^{(k)}$ is the diagonal singular value matrix. $\tilde{\mathbf{V}}_s^{(k)}$ and $\tilde{\mathbf{V}}_n^{(k)}$ denote the right singular matrices corresponding to nonzero singular values and zero singular values, respectively, and $\tilde{\mathbf{D}}_s^{(k)}$ is the diagonal matrix consisting of nonzero singular values.

Finally, the total transmit weight of BD algorithm is given by

$$\mathbf{W}_{\text{BD}}^{(k)} = \tilde{\mathbf{V}}_n^{(k)}\tilde{\mathbf{V}}_s^{(k)}. \quad (17)$$

When using $\mathbf{W} = [\mathbf{W}_{\text{BD}}^{(1)}, \dots, \mathbf{W}_{\text{BD}}^{(N_U)}]$ and $\mathbf{W}_r^{(k)} = (\tilde{\mathbf{U}}^{(k)})^H$ in Eq.(8), the receive signal of user k , $\mathbf{y}^{(k)}(t)$, is expressed as

$$\begin{aligned} \mathbf{y}^{(k)}(t) &= (\tilde{\mathbf{U}}^{(k)})^H \cdot \left(\mathbf{H}^{(k)}\mathbf{W}_{\text{BD}}^{(k)}\mathbf{s}^{(k)}(t) + \mathbf{n}^{(k)}(t) \right) \\ &= \tilde{\mathbf{D}}_s^{(k)}\mathbf{s}^{(k)}(t) + (\tilde{\mathbf{U}}^{(k)})^H\mathbf{n}^{(k)}(t). \end{aligned} \quad (18)$$

In this way, inter-substream interference is eliminated in the multi-substream transmission of each user.

2.4 Block Maximum SNR (BMSN) Algorithm

BD algorithm is understood to obtain the transmit weight $\mathbf{W}^{(k)}$ for user k from the following constrained minimization:

$$\begin{aligned} \min_{\mathbf{W}^{(k)}} &\|\tilde{\mathbf{H}}^{(k)}\mathbf{W}^{(k)}\|_F^2 \\ \text{subject to} &\|\mathbf{W}^{(k)}\|_F^2 = \text{constant} \end{aligned} \quad (19)$$

where $\tilde{\mathbf{H}}^{(k)}$ is the channel matrix of Eq.(13). It is found from the above optimization problem that BD algorithm is devoted to reduce inter-user interference to other users. This is similar to the criterion of the power inversion adaptive array [40]–[42].

On the other hand, the BMSN algorithm is based on the minimization of interference to other users while maintaining the high gain of one's own channel [21]. Therefore, it leads to performance improvement of the eigenmode transmission of each user. The principle of BMSN algorithm to obtain the transmit weight $\mathbf{W}^{(k)}$ for user k is described as follows:

$$\begin{aligned} \min_{\mathbf{W}^{(k)}} &\|\tilde{\mathbf{H}}^{(k)}\mathbf{W}^{(k)}\|_F^2 \\ \text{subject to} &\mathbf{H}^{(k)}\mathbf{W}^{(k)} = \mathbf{T}^{(k)} \end{aligned} \quad (20)$$

where $\mathbf{T}^{(k)}$ is a constant matrix corresponding to the desired channel matrix of each user. Equation $\mathbf{H}^{(k)}\mathbf{W}^{(k)} = \mathbf{T}^{(k)}$ is referred to as the beamforming condition for transmit weights. Furthermore, this problem is mathematically equivalent to the maximum SNR principle provided by

$$\begin{aligned} \max_{\mathbf{W}^{(k)}} &(\text{SNR}) \\ \text{with} \quad \text{SNR} &= \frac{\|\mathbf{H}^{(k)}\mathbf{W}^{(k)}\|_F^2}{\|\tilde{\mathbf{H}}^{(k)}\mathbf{W}^{(k)}\|_F^2} \\ &= \frac{\text{tr}\{(\mathbf{W}^{(k)})^H(\mathbf{H}^{(k)})^H\mathbf{H}^{(k)}\mathbf{W}^{(k)}\}}{\text{tr}\{(\mathbf{W}^{(k)})^H(\tilde{\mathbf{H}}^{(k)})^H\tilde{\mathbf{H}}^{(k)}\mathbf{W}^{(k)}\}}. \end{aligned} \quad (21)$$

This is similar to the maximum SNR adaptive array [40], [41], [43].

The solution of this problem is obtained by differentiating the SNR of Eq.(21) with $(\mathbf{W}^{(k)})^*$ and equating the resultant to zero. Thereby, we have the following equation:

$$\begin{aligned} &(\tilde{\mathbf{H}}^{(k)})^H\tilde{\mathbf{H}}^{(k)}\mathbf{W}^{(k)} \\ &= \frac{\text{tr}\{(\mathbf{W}^{(k)})^H(\tilde{\mathbf{H}}^{(k)})^H\tilde{\mathbf{H}}^{(k)}\mathbf{W}^{(k)}\}}{\text{tr}\{(\mathbf{W}^{(k)})^H(\mathbf{H}^{(k)})^H\mathbf{H}^{(k)}\mathbf{W}^{(k)}\}}(\mathbf{H}^{(k)})^H\mathbf{H}^{(k)}\mathbf{W}^{(k)} \\ &= \frac{1}{\text{SNR}}(\mathbf{H}^{(k)})^H\mathbf{H}^{(k)}\mathbf{W}^{(k)}. \end{aligned} \quad (22)$$

The above equation means a generalized eigenvalue problem of $(\tilde{\mathbf{H}}^{(k)})^H\tilde{\mathbf{H}}^{(k)}$ and $(\mathbf{H}^{(k)})^H\mathbf{H}^{(k)}$ with eigenvalues equal to $1/\text{SNR}$. However, we use here the beamforming condition $\mathbf{H}^{(k)}\mathbf{W}^{(k)} = \mathbf{T}^{(k)}$ in Eq.(22) for reducing the computational complexity. Consequently, we have

$$(\tilde{\mathbf{H}}^{(k)})^H\tilde{\mathbf{H}}^{(k)}\mathbf{W}^{(k)} = \frac{1}{\text{SNR}}(\mathbf{H}^{(k)})^H\mathbf{T}^{(k)}, \quad (23)$$

and we obtain the following solution for transmit weight with a scalar $\mu = 1/\text{SNR}$

$$\mathbf{W}_{\text{opt}}^{(k)} = \mu\{(\tilde{\mathbf{H}}^{(k)})^H\tilde{\mathbf{H}}^{(k)} + \alpha\mathbf{I}\}^{-1}(\mathbf{H}^{(k)})^H\mathbf{T}^{(k)} \quad (24)$$

where α is a diagonal loading of positive scalar for obtaining

inverse matrix. In addition, α has a function of controlling the pattern null depth to other users [44]. We call α the pseudo noise because it is quite similar to the noise in MMSE algorithm mentioned in Sect. 2.2. The scalar μ is determined from constant transmit power condition.

Concerning the constant matrix $\mathbf{T}^{(k)}$,

$$\mathbf{T}^{(k)} = \mathbf{I}_{N_R} \quad (25)$$

is a simple and most likely candidate from considering the eigenmode transmission of each user [21]. In this paper, $\mathbf{T}^{(k)} = \mathbf{I}_{N_R}$ of Eq.(25) is adopted consistently for BMSN algorithm.

Hence, user-by-user block MSN can be realized when $\mathbf{W}^{(k)} = \mathbf{W}_{\text{opt}}^{(k)}$. Afterwards, we follow the same process as the BD algorithm. Regarding the channel matrix $\tilde{\mathbf{H}}^{(k)} = \mathbf{H}^{(k)} \mathbf{W}_{\text{opt}}^{(k)}$ as that of single user MIMO for user k , we employ eigenmode transmission beamforming (EM-BF) for the matrix $\tilde{\mathbf{H}}^{(k)}$. Finally, the total transmit weight of BMSN algorithm is given by

$$\mathbf{W}_{\text{BMSN}}^{(k)} = \mathbf{W}_{\text{opt}}^{(k)} \tilde{\mathbf{V}}_s^{(k)} \quad (26)$$

where $\tilde{\mathbf{V}}_s^{(k)}$ denotes the matrix consisting of right singular vectors corresponding to nonzero singular values of $\tilde{\mathbf{H}}^{(k)}$.

2.5 Issue on BD and BMSN Algorithms

Figure 3 shows the BER versus Signal to Noise power Ratio (SNR) when the BD and BMSN algorithms are applied to the MU-MIMO system with $(N_T, N_R, N_U) = (16, 2, 8)$. In the BMSN algorithm, α is equal to 10^{-2} . We assume i. i. d. Rayleigh flat fading as the propagation characteristics. The notation [4, 0], [3, 1] and [2, 2] in Fig. 3 denote the combinations of bits/symbol/user for each data stream. Hence, total bits/symbol/user is four, and BPSK, QPSK, 8PSK and 16QAM are used for the modulation for each bit rate. The notation [4, 0] means that only 16QAM is transmitted. It can be seen in Fig. 3 that the BER performance by [4, 0] is enhanced compared to those by [3, 1] and [2, 2] in both BD and BMSN algorithms. This means that the single-stream transmission corresponding to the largest eigenvalue provides the best BER performance.

Figure 4 shows the eigenvalue distributions of the BD and BMSN algorithms with $(N_T, N_R, N_U) = (16, 2, 8)$, in which (a) and (b) correspond to SNR=15 dB and SNR=30 dB, respectively. As shown in these figures, the 2nd eigenvalues (λ_2) of BD and BMSN both are very small compared to individual 1st eigenvalues (λ_1). Particularly, when SNR is low as shown in Fig.4(a), the 2nd eigenvalues are extremely small. In addition, it is found that BMSN is more serious than BD in that problem. Therefore, it leads to the fact that an actual modulation might not be assigned for the second data stream in the adaptive modulation scheme.

3. User Antenna Selection in BD and BMSN Algorithms

Figure 5 shows the concept of user antenna selection (AS)

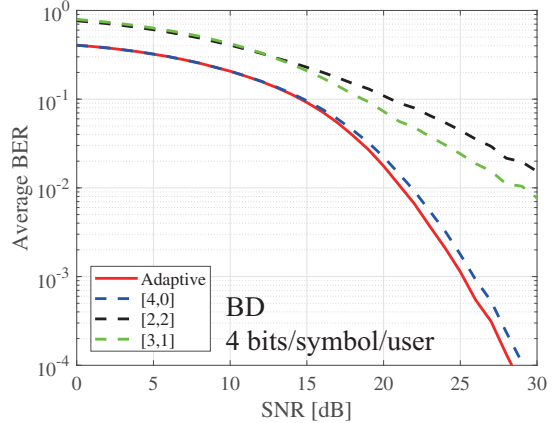

(a) BD algorithm

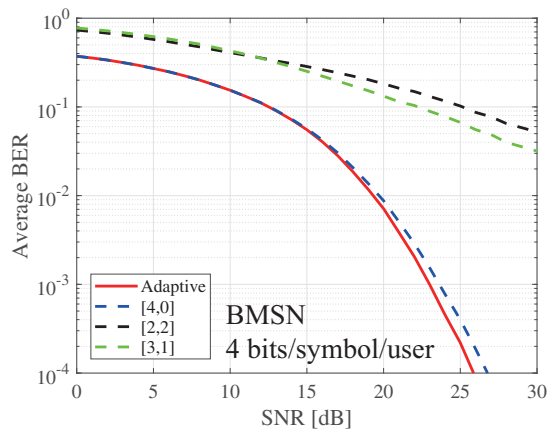

(b) BMSN algorithm with $\alpha = 10^{-2}$

Fig. 3 SNR versus BER ($N_T = 16, N_R = 2, N_U = 8$).

method in the BD and BMSN algorithms [22]. In this figure, $\mathbf{H}_S^{(k)} \in \mathbb{C}^{(N_R-1) \times N_T}$ represents the channel matrix of user k after the antenna selection and also $\mathbf{W}_S^{(k)} \in \mathbb{C}^{N_T \times (N_R-1)}$ the BD or BMSN weight matrix for the inter-user interference cancellation of user k after the antenna selection. In the BD and BMSN algorithms with user antenna selection, denoted by BD-AS and BMSN-AS, the receive antenna with the smallest instantaneous SNR for each UT is not used for block diagonalization or beamforming. As a result, the BS-AS and BMSN-AS algorithms can reduce the number of pattern nulls towards the interfering users.

Table 1 shows the number of pattern nulls (N_A) for the inter-user interference cancellation and the equivalent number of transmit antennas (N_{TE}) for each user by the BD and BMSN algorithms, when $N_U \geq 2$. Note that N_R is assumed to be identical among each user. As found from Table 1, when N_U is increased, N_A is increased and hence N_{TE} is decreased. When N_T is equal to $N_U \cdot N_R$, N_{TE} of BD and BMSN is equal to N_R . Therefore, the transmit diversity effect is not expected in such a scenario where the conventional BD and BMSN algorithms are used. On the other hand, although the number of received antennas is reduced to $N_R - 1$, the transmit diversity is expected by

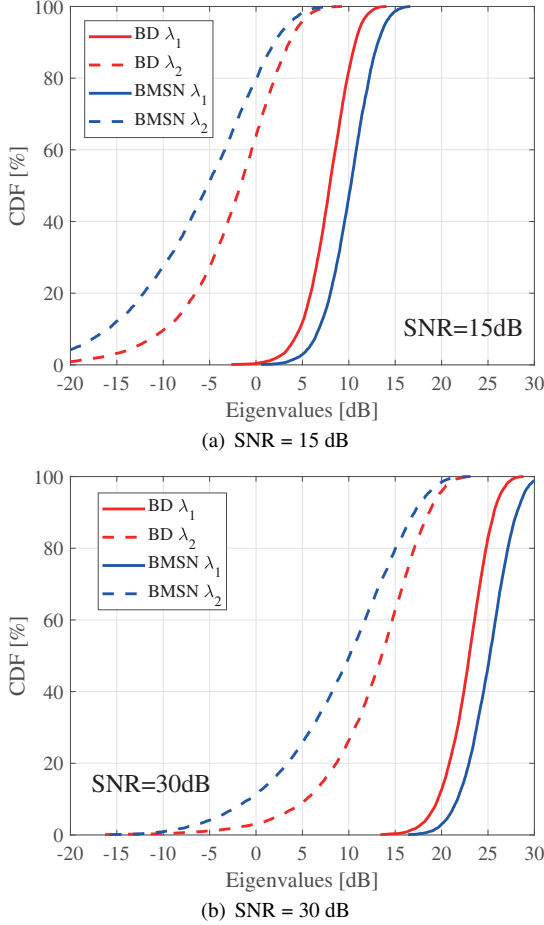

Fig. 4 Comparison of eigenvalue distribution ($N_T = 16$, $N_R = 2$, $N_U = 8$).

Table 1 Number of pattern nulls (N_A) and equivalent number of transmit antennas (N_{TE}).

	BD and BMSN	BD-AS and BMSN-AS
N_A	$(N_U - 1) \times N_R$	$(N_U - 1) \times (N_R - 1)$
N_{TE}	$N_T - (N_U - 1) \times N_R$	$N_T - (N_U - 1) \times (N_R - 1)$

(AS: antenna selection)

the BD-AS and BMSN-AS. This is because N_A is decreased and so N_{TE} is increased as shown in Table 1. When N_T is equal to $N_U \cdot N_R$, N_{TE} of BD-AS and BMSN-AS is equal to $N_R + N_U - 1$ which is larger than BD and BMSN by $N_U - 1$. It means the larger the number of users is, the more the transmit diversity effect of BD-AS and BMSN-AS grows.

The SNR, according to which user antenna selection is carried out, is obtained by the channel matrix between the BS and each UT before calculating the transmit weights. Then, the SNR for the receiver i ($i = 1 \sim N_R$) at the UT k ($k = 1 \sim N_U$), $\gamma_i^{(k)}$, is expressed as

$$\gamma_i^{(k)} = \frac{\sum_{j=1}^{N_T} |h_{ij}^{(k)}|^2}{N_T \sigma^2}, \quad (27)$$

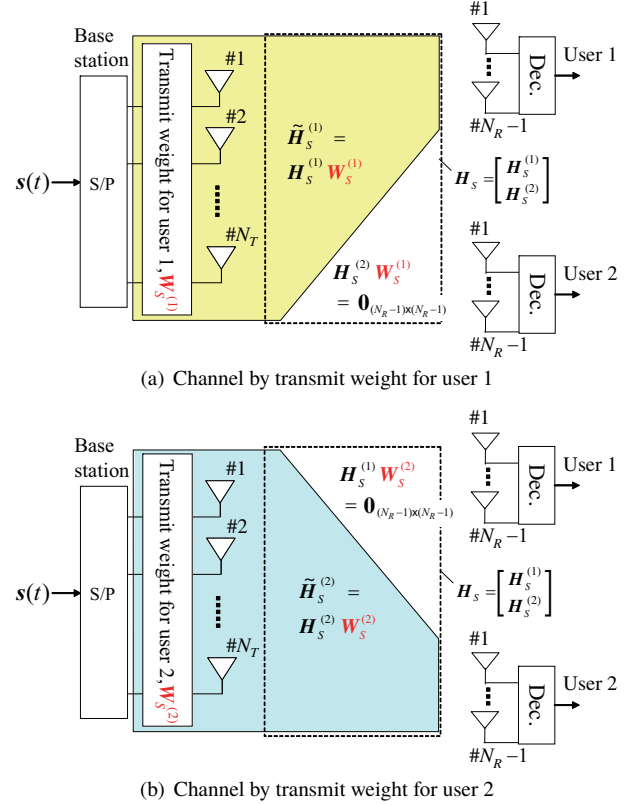

Fig. 5 Spatial channel by user antenna selection in BD and BMSN algorithms ($N_U = 2$).

where $h_{ij}^{(k)}$ is the channel response for the j -th transmitter and i -th receiver for the UT k . σ^2 is the noise power.

4. Achievable Bit Rate and Throughput Considering IEEE802.11ac Based Modulation Schemes

First, the BER performance is evaluated for typical linear control algorithms. Figure 6 shows the comparison in the BER versus SNR among linear transmission control algorithms. In the BMSN and BMSN-AS, α is equal to 10^{-2} . We assume i. i. d. Rayleigh flat fading as the propagation characteristics. The bit rate is assumed to be 4 bits/symbols/user and $(N_T, N_R, N_U) = (16, 2, 8)$ in this figure. Adaptive modulation is employed according to the eigenvalues by BD, BMSN, and ZF, and the modulation scheme with the minimum BER is selected for each transmission trial [39]. As can be seen in Fig. 6, BD and BMSN obviously outperform ZF. Furthermore, BD-AS and BMSN-AS which both use user antenna selection are the same in BER, and they achieve considerable improvement over BD and BMSN.

Next, the throughput considering IEEE802.11ac based modulation schemes is evaluated. Table 2 shows the simulation parameters. As shown in Table 2, N_T is equal to $N_R \times N_U$. In order to consider the path loss, the ITR model, which is one of typical models in indoor scenario with 2 to 5 GHz bands, is used [45]. In order to evaluate the basic performance of the antenna selection, i. i. d. Rayleigh flat

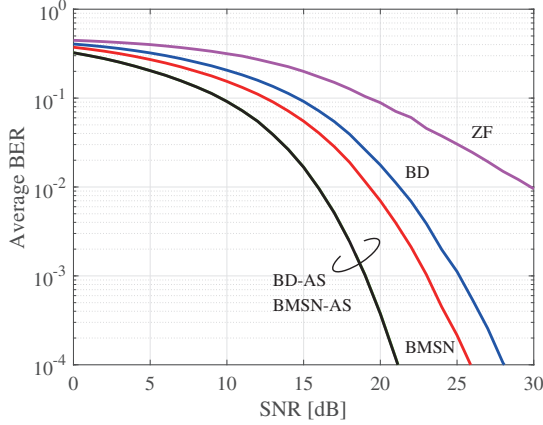

Fig. 6 BER versus SNR of linear transmission control algorithms ($N_T = 16$, $N_R = 2$, $N_U = 8$).

fading environment assumed for each sub-carrier in OFDM signals.

Figure 7 shows the access control procedure for MU-MIMO transmission [35]. In Fig. 7, the NPDA (Null Data Packet Announcement) and NDP (Null Data Packet) are used for the request of CSI estimation. The BR (Beamforming Report) and BRP (Beamforming Report Polling) are used for CSI feedback, which might give a large overhead in MU-MIMO system. The BA (Block ACK) and BAR (Block ACK Request) are used for the acknowledgement (ACK) for the completion on the MU-MIMO transmission. The detailed procedure in MU-MIMO transmission considering media access control (MAC) is explained in [35]. The throughput is obtained by using the modulation scheme, the packet size and the control signals shown in Fig. 7 and Table 2. In order to enhance the throughput, the frame aggregation is effective, hence the data size is much greater than the conventional packet data size in this study.

In this paper, we evaluate the achievable bit rate (ABR) before the throughput considering IEEE802.11ac based modulation schemes. The throughput is the data amount of the payload in the data frame, among the channel occupation time including the overhead as shown in Fig. 7, and it indicates the effective throughput. Parameters of the physical (PHY) layer and MAC header used those of the IEEE 802.11ac standard [18].

The ABRs by the conventional BD and BMSN algorithms (C_{BD} and C_{BMSN}) are obtained as

$$C_{BD} = \sum_{i=1}^2 \log_2 \left(1 + \frac{\tilde{\lambda}_{BD}(i)}{N_T \sigma^2} \right), \quad (28)$$

$$C_{BMSN} = \sum_{i=1}^2 \log_2 \left(1 + \frac{\tilde{\lambda}_{BMSN}(i)}{N_T \sigma^2} \right) \quad (29)$$

and when the user antenna selection (AS) is employed, they (C_{BD-AS} and $C_{BMSN-AS}$) are obtained as

$$C_{BD-AS} = \log_2 \left(1 + \frac{\tilde{\lambda}_{BD-AS}}{N_T \sigma^2} \right), \quad (30)$$

Table 2 Major simulation parameters.

Number of transmit antennas (N_T)	16
Number of receive antennas (N_R)	2
Number of users (N_U)	8
Frequency (f_c)	5200 MHz
Bandwidth	40 MHz
Transmit distance (d)	1 ~ 50 m
Path loss (L)	$31 \log_{10}(d) + 20 \log_{10}(f_c) - 28$ [45]
Transmit power	19 dBm
Antenna gain	2 dBi
NPDA (Null Data Packet Announcement)	104 ~ 120 μ s
NDP (Null Data Packet)	104 ~ 124 μ s
BR (Beamforming Report)	172 ~ 2600 μ s
BRP (BR Polling)	100 ~ 116 μ s
BA (Beamforming ACK)	40 ~ 64 μ s
BAR (Beamforming ACK Request)	100 ~ 116 μ s
SIFS (for BR)	272 μ s
SIFS (for BA)	16 ~ 240 μ s
DIFS	34 μ s
Backoff (Average time)	67.5 μ s
Frame aggregation	63,000 Byte

Table 3 Relationship between the modulation scheme and the transmission rate (40 MHz).

MCS index	Modulation scheme	Coding rate	Rmin [dBm]	TR [Mbps]	SNR [dB]
0	BPSK	1/2	-79	15	6
1	QPSK	1/2	-76	30	9
2	QPSK	3/4	-74	45	11
3	16-QAM	1/2	-71	60	14
4	16-QAM	3/4	-67	90	18
5	64-QAM	2/3	-63	120	22
6	64-QAM	3/4	-62	135	23
7	64-QAM	5/6	-61	150	24
8	256-QAM	3/4	-56	180	29
9	256-QAM	5/6	-54	200	31

$$C_{BMSN-AS} = \log_2 \left(1 + \frac{\tilde{\lambda}_{BMSN-AS}}{N_T \sigma^2} \right) \quad (31)$$

where $\tilde{\lambda}_{BD}(i)$ and $\tilde{\lambda}_{BMSN}(i)$ ($i = 1, 2$) are eigenvalues which are obtained by conventional BD and BMSN algorithms, respectively, and they have distribution shown in Fig. 4. On the other hand, $\tilde{\lambda}_{BD-AS}$ and $\tilde{\lambda}_{BMSN-AS}$ are eigenvalues of BD and BMSN with user antenna selection, respectively. Note that only 1st eigenvalue exists for the algorithms with user antenna selection because N_R is two.

Table 3 represents the relationship between transmission rate (TR) and SNR in IEEE802.11ac (40MHz mode) [18]. The SNR shown in Table 3 is the value in case the BER with IEEE802.11ac based single stream transmission is zero. Hence, error correction and bit interleave are considered for the relationship between the SNR and modulation scheme in Table 3. Next, because eigenvalues by BD and BSMN algorithms denote the received power, the modulation schemes can be selected by only $\lambda/(N_T \sigma^2)$ [22]. Here, λ and σ^2 are the eigenvalue and noise power, respectively.

Figures 8 and 9 show the cumulative distribution function (CDF) of ABRs per user when the average SNRs are

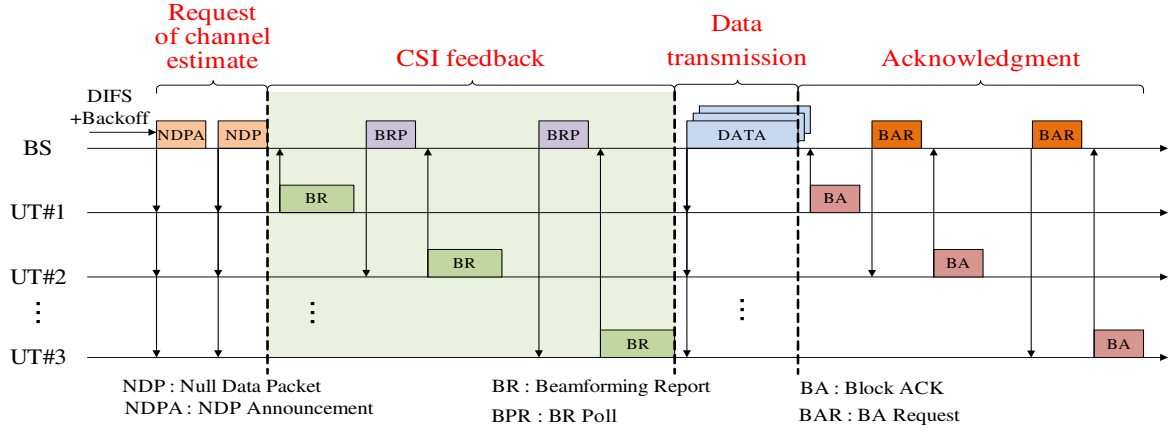

Fig. 7 Access control procedure for MU-MIMO transmission.

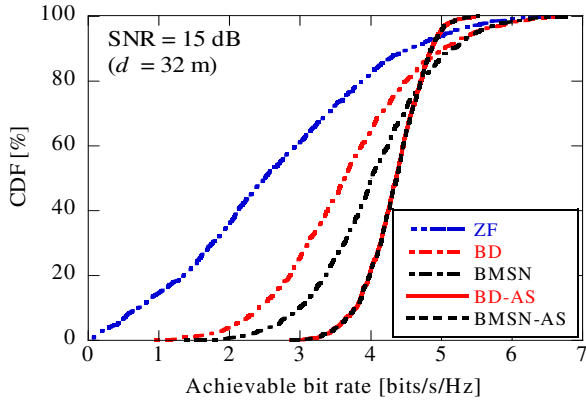

Fig. 8 CDF of achievable bit rate (SNR = 15 dB, $d = 32$ m).

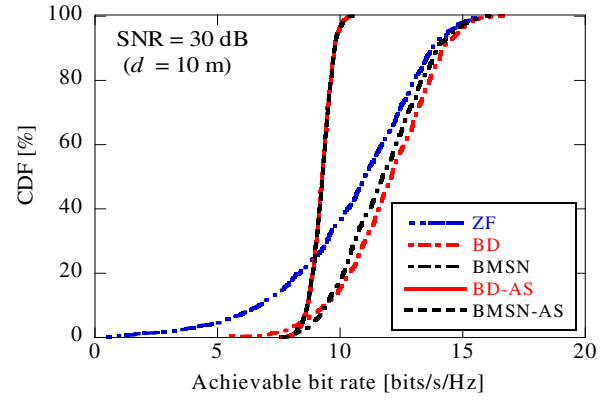

Fig. 9 CDF of achievable bit rate (SNR = 30 dB, $d = 10$ m).

15 dB and 30 dB, respectively. SNR=15 dB and 30 dB correspond to the transmission distance $d = 32$ m and 10 m, respectively. As shown in Fig. 8, BD and BMSN obviously outperform ZF in terms of the ABR. Furthermore, BD-AS and BMSN-AS which both use user antenna selection are the same in ABR and the high ABRs by BD-AS and BMSN-AS are observed compared to the ABRs by BD and BMSN without user antenna selection. On the other hand, when the average SNR is 30 dB in Fig. 9, the small ABRs by BD-AS and BMSN-AS are observed compared to the ABRs by BD and BMSN without user antenna selection. The reason why the BD-AS and BMSN-AS have the same ABR distribution is that they have individually only 1st eigenvalues that are in the same distribution.

Figure 10 shows the ABRs per user versus the transmission distance. The CDF value is 10%. As can be seen in this figure, BD and BMSN obviously outperform ZF regardless of the transmission distance d . Moreover, when d is greater than 16 m, ABRs by the BD-AS and BMSN-AS are higher than those by the BD and BMSN. Because the improvement of ABR at the cell edge is more important than that at neighborhood base station, the user antenna selection is effective from a point of view in enlarging the service area.

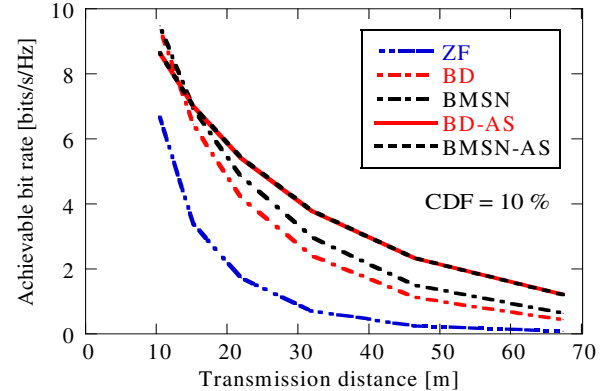

Fig. 10 Achievable bit rate versus transmission distance (CDF = 10%).

Next, the throughput considering IEEE802.11ac based modulation schemes is evaluated. Figures 11 and 12 show the CDF of the total throughput considering 8 users when the average SNRs are 15 dB and 30 dB, respectively. As shown in Fig. 11, BD-AS and BMSN-AS which both use user antenna selection are the same in the throughput and the improvement of throughput by BD-AS and BMSN-AS is

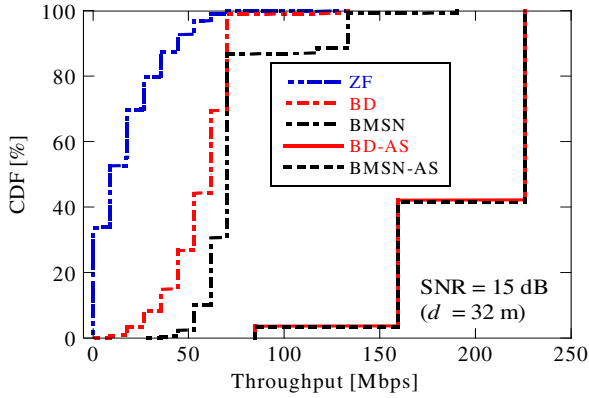

Fig. 11 CDF of throughput (SNR = 15 dB, $d = 32$ m).

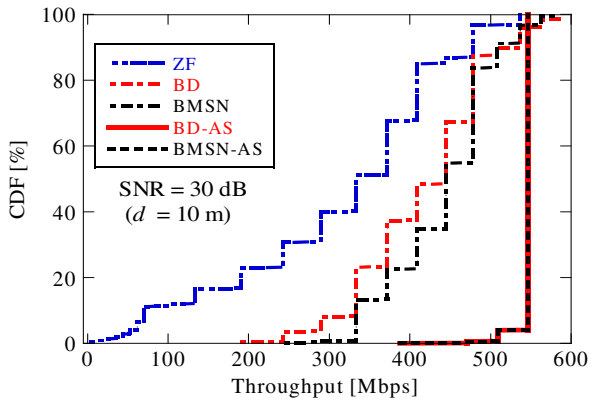

Fig. 12 CDF of throughput (SNR = 30 dB, $d = 10$ m).

twice or more in comparison with BD and BMSN without antenna selection. Moreover, even if the average SNR is 30 dB, the throughputs by BD-AS and BMSN-AS are improved compared to those by BD and BMSN with the low CDF.

Figure 13 shows the throughput versus the transmission distance. The average throughput, when all the users ($N_U = 8$) are considered, is plotted for each algorithm in this figure. As can be seen in Fig 13, BD-AS and BMSN-AS outperform the other transmission algorithms (ZF, BD and BMSN) regardless of the transmission distance. It is because the number of data streams is only one in the case of user antenna selection and also the amount of information regarding the CSI feedback by BD-AS and BMSN-AS is smaller than ZF, BD and BMSN. Furthermore, because the higher order modulation schemes can be used for first data stream by using user antenna selection, the ratio of control signals for total data size can be reduced. Therefore, from a point of view in the MAC protocol, it is shown that the antenna selection is effective for reducing the overhead in MU-MIMO transmission.

The above results are explained by using the eigenvalue distribution. Tables 4 and 5 shows the eigenvalues by BD, BD-AS, BMSN and BMSN-AS when the CDF = 50 %.

When the average SNR is 15 dB, as can be seen in Tables

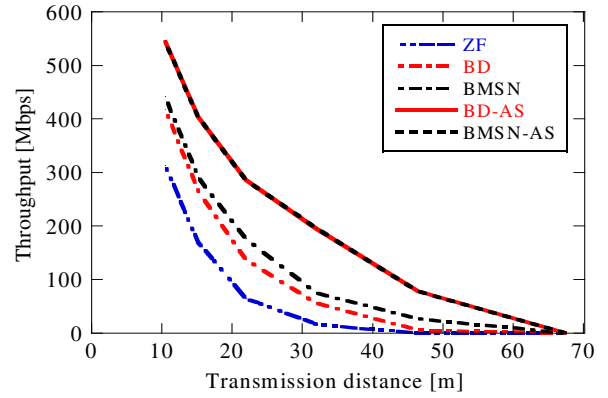

Fig. 13 Average throughput versus transmission distance.

Table 4 Eigenvalues with BD and BD-AS (CDF = 50%).

	BD		BD-AS
	$\frac{\lambda_{BD(1)}}{N_T \sigma^2}$ [dB]	$\frac{\lambda_{BD(2)}}{N_T \sigma^2}$ [dB]	$\frac{\lambda_{BD-AS}}{N_T \sigma^2}$ [dB]
SNR=15 dB	7.94	-1.80	12.9
SNR=30 dB	23.0	13.5	27.9

Table 5 Eigenvalues with BMSN and BMSN-AS (CDF = 50%).

	BMSN		BMSN-AS
	$\frac{\lambda_{BMSN(1)}}{N_T \sigma^2}$ [dB]	$\frac{\lambda_{BMSN(2)}}{N_T \sigma^2}$ [dB]	$\frac{\lambda_{BMSN-AS}}{N_T \sigma^2}$ [dB]
SNR=15 dB	10.2	-5.31	12.9
SNR=30 dB	25.4	9.99	27.9

4 and 5, even BPSK modulation for the second data stream by BD and BMSN cannot be assigned, which is confirmed with Table 3. When the average SNR is 30 dB, as found from Tables 4 and 5, the second eigenvalues by BD and BMSN 13.5 dB and 9.99 dB, respectively. In this case, the modulation scheme can be assigned for the second data stream and the further high order modulation scheme can be assigned for the first data stream as shown in Table 3. On the other hand, the modulation scheme is assigned even in the SNR = 15 dB, when the user antenna selection is applied for BD and BMSN. Therefore, it is found that the user antenna selection is effective when the second eigenvalue is very small and any modulation scheme is not assigned.

Next, we focus on the comparison between BD and BMSN without the user antenna selection. As shown in Sect. 2.5, the first eigenvalue by BMSN is greater than that by BD, but the second eigenvalue by BMSN is smaller than that by BD, which is also verified in Tables 4 and 5. Because the second eigenvalue cannot be used in the low SNR, the BMSN obtains the higher transmission rate and therefore higher throughput by BMSN is obtained compared to that by BD. Hence, the pseudo-noise α in the BMSN is a very important key parameter for achieving the higher throughput in actual wireless systems.

5. Discussion

As demonstrated in the previous section, BD algorithm tries

to create deep pattern nulls to other users to suppress completely the inter-user interference. At the price of it, BD has the 2nd eigenvalue of channel matrix decreased, resulting in the degraded transmission rate. To moderate the properties of BD to make the deep pattern nulls, BMSN was proposed which maintains the high channel gain of desired user simultaneously with making pattern nulls to other interfering users. We have confirmed that BMSN outperforms BD because BMSN enlarges the 1st eigenvalue of channel matrix as a result of maximizing the SNR in the channel matrix. However, the 2nd eigenvalue of BMSN is even more decreased than that of BD. Consequently, the data stream corresponding to the 2nd eigenvalue cannot be utilized effectively in the MU-MIMO transmission with BMSN. Although BD has the same characteristics as BMSN, the behavior of BMSN deteriorates more seriously than that of BD.

To treat that issue, the user antenna selection (AS) method was incorporated into the BD and BMSN that are referred to as BD-AS and BMSN-AS, respectively. These algorithms do not utilize the sub-stream corresponding to the smallest eigenvalue by selecting appropriate user antennas for receiving data streams at each UT. When $N_R = 2$, the either of two user antennas is selected for reception.

It has been verified via BER evaluation that the BD-AS and BMSN-AS algorithms are effective compared to the BD and BMSN algorithms. In addition, it has been clarified that the BD-AS and BMSN-AS algorithms are effective in the low SNR because the smallest eigenvalues of channel matrix cannot be used in the conventional BD and BMSN algorithms even if the user scheduling is used on actual modulation schemes.

BMSN and BMSN-AS have a function of controlling the pattern null depth with the pseudo-noise. In this paper, we let the pseudo-noise (α) equal to a constant of 10^{-2} from experience of some simulations. Since the BMSN and BMSN-AS are affected by α , a further detailed examination on the BMSN and BMSN-AS with variation of α is required, which will be our future works. In addition, we will try to incorporate the adaptive control of pseudo-noise into BMSN and BMSN-AS [44]. We will expect that the adaptive control scheme can improve furthermore the performance of BMSN and BMSN-AS.

The effect of antenna selection method greatly depends on the given propagation characteristics. As one specific example, let us assume the line of sight MIMO (LoS-MIMO) [46],[47]. The use of antenna selection is not meaningless at the optimal element spacing which gives the maximum channel capacity in LoS-MIMO channel, because all the eigenvalues are identical in LoS-MIMO channel. On the other hand, the antenna selection is effective for Nakagami-rice fading channel, because the eigenvalues in Nakagami-rice fading channel are much smaller than those in Rayleigh fading channel in Sect. 4.

Because the number of receive antennas, N_R at the UTs is two in the evaluation in Sect. 4, the antenna is only one after the antenna selection. However, there might be a change to improve the transmission rate when the reduced

antenna number is greater than one. Key point to solve this question is propagation characteristics. We confirmed that the reduced number is one when considering i. i. d. Rayleigh fading environment even if N_R is greater than two. On the other hand, when considering a highly correlated channel or assuming large rice factor, K , the optimal reduced number of antennas is not necessarily one. The optimum number on the antenna selection should be evaluated as a future work.

The user antenna selection will be effective particularly when the number of users is increased with massive antennas at the base station. In order to further improve the frequency utilization of future wireless systems with MU-MIMO transmissions, the concept of massive MIMO was recently proposed [48]–[51]. In massive MIMO systems, the number of antennas at the base station is much larger than the number of UT antennas and the number of UTs. Massive MIMO enables low-complexity signal processing because the inter-user interference is easily mitigated by the resulting high beamforming resolution [49].

Unlike the condition in *conventional* massive MIMO system, let us assume that the number of users is almost the same as the number of antennas at the base station in massive MIMO system. This is a situation where the degree of freedom is not sufficiently exploited in the *conventional* massive MIMO system. An actual degree of freedom in massive MU-MIMO transmission is not $N_T - 1$ when considering the sum rate is maximized with linear pre-coding algorithms such as ZF, MMSE, BD, and BMSN. The user antenna selection will be one of countermeasures for improving the sum transmission rate in such environments. In addition, the use of dual-polarization is also essential as the spatial division multiplexing inside of each user for improving the sum transmission rate when considering a huge number of users, which is required for future wireless communication systems.

In this paper, we have discussed the importance of the performance of the whole wireless system. However, it is important how to combine various wireless communication technologies and leads to development of the next generation network. Wireless transmission has lower bandwidth utilization efficiency than wired transmission, hence we have realized transmission efficiency improvement and transmission speed improvement within a limited frequency band by various techniques.

As shown in this paper, MU-MIMO transmission technology is indispensable for high-speed transmission. However, even if the transmission rate of the PHY layer is increased by using these techniques, there is a problem that the transmission efficiency is lowered due to the overhead expended in the access control protocol in the MAC layer, and the transmission speed cannot be sufficiently utilized. Compared to the wired LAN, there is a great difference in transmission efficiency, and in the conventional wireless LAN systems, only approximately 60% transmission efficiency can be obtained. Even if the frame aggregation is applied, the throughput obtained in this paper is almost 50 % compared to transmission rate in the PHY layer. Even if the

CSI feedback is eliminated by using the channel reciprocity between the transmitter and receiver, the MAC efficiency cannot be dramatically improved when considering massive MIMO [35]. Therefore, new efficient methods without depending the CSI should be developed [52], [53].

As a difference between the wired LAN and the wireless LAN, the wired communication is performed in full duplex whereas the wireless is half duplex communication. In wireless communication sharing the bandwidth in time division by multiple users, the communication efficiency decreases as compared with wired communication, regardless of SU-MIMO or MU-MIMO. In addition, wired LANs do not interfere with each other and there is no need to consider packet conflict, whereas in wireless LANs, the collision avoidance function and the retransmission process after collision have a large overhead, which causes reduction in transmission efficiency. These issues have been studied separately on the physical layer technology and upper layer protocol technologies such as the MAC layer and TCP / IP.

Therefore, it is necessary to consider new layer integration technology (or beyond cross layer technology) considering transmission efficiency. The beyond cross layer technology is a network design and control method that makes full use of the overall capability on wireless network systems such as transmission medium, network, service and user information. In order to realize the next generation network system, we will aim for the beyond cross layer technology based on new layer integration / cooperation technology.

6. Conclusion

This paper has demonstrated the effect of antenna selection (AS) at the UT on the performance of BD and BMSN algorithms, with the idea being to reduce the number of pattern nulls for the inter-user interference (IUI). The calculation complexity of the BD and BMSN with AS method (BD-AS and BMSN-AS) are almost the same as the conventional ones, because the AS method needs the SNR measurement for each user while the combination of user and antenna scheduling requires the CSIs for all possible users for the scheduling.

First, a BER evaluation showed that the BMSN with positive beamforming to desired users outperforms the BD, when the numbers of transmit antennas, receive antennas and users are 16, 2 and 8, respectively. In comparison between BD and BD-AS, the SNR improvement of 6 dB at $BER = 10^{-3}$ by the BD-AS algorithm is observed compared to the conventional BD. Similarly, in comparison between BMSN and BMSN-AS, the BMSN-AS reveals the SNR improvement of 4 dB at $BER = 10^{-3}$ over the conventional BMSN. Moreover, it is quite interesting that the BD-AS and BMSN-AS algorithms have the same BER performance. In this way, the effect of AS method in BD and BMSN is confirmed.

Next, the achievable bit rates of BD and BMSN algorithms with ideal user scheduling were evaluated. The number of equivalent receive antennas is reduced to only

one by the AS method when the number of antennas at the UT is two. However, it is shown that the achievable bit rates of the BD-AS and BMSN-AS algorithms are higher than those of the conventional BD and BMSN algorithms when the transmission distance is greater than 16 m even in the condition on 8-user scheduling. Moreover, it is shown that the user antenna selection is effective in the edge of service area.

Finally, we carried out a throughput evaluation considering MAC protocol that includes the overhead on the CSI estimation and feedback. Since the transmission efficiency is enhanced due to the reduced number of data streams and larger eigenvalue by the diversity effect, the throughputs by BD-AS and BMSN-AS are over twice compared with those by the conventional BD and BMSN when the SNR is high.

Because the purpose of the method in [32], [33] is basically the same as that of the AS method, the quantitative comparison in terms of the BER performance and calculation complexity should be evaluated as future work.

Acknowledgments

Part of this work was supported by KAKENHI, Grant-in-Aid for Scientific Research (B) (17H03262, 17H01738) and Scientific Research (C) (15K06060). The authors would like to thank Mr. Morino of Nippon Institute of Technology and Mr. Yaku of Niigata University for the help on the evaluation.

References

- [1] G. J. Foschini and M. J. Gans, "On limits of wireless communications in a fading environment when using multiple antennas," *Wireless Personal Commun.*, vol.6, pp.311–335, 1998.
- [2] I. E. Telatar, "Capacity of multiantenna Gaussian channels," *Euro. Trans. Telecommun.*, vol.1, no.6, Nov/Dec. 1999.
- [3] A. Zelst and T. C. W. Schenk, "Implementation of a MIMO OFDM based wireless LAN systems," *IEEE Trans. Signal Process.*, Vol.52, No.2, pp.483–494, Feb. 2004.
- [4] A. Paulraj, R. Nabar, and D. Gore, "Introduction to space-time wireless communications," Cambridge University Press 2003.
- [5] T. Ohgane, T. Nishimura, and Y. Ogawa, "Applications of Space Division Multiplexing and Those Performance in a MIMO Channel," *IEICE Trans. Commun.* Vol.E88-B, No.5, pp.1843–1851, May 2005.
- [6] "MIMO Implementation Aspects," *Proc. IEEE RAWCON, Workshop, WS2*, Sept. 2004.
- [7] H. Taoka, K. Dai, K. Higuchi and M. Sawahashi, "Field Experiments on Ultimate Frequency Efficiency Exceeding 30 Bit/Second/Hz Using MLD Signal Detection in MIMO-OFDM Broadband Packet Radio Access," *Proc. of IEEE VTC2007-Spring*, pp.2129–2134, Apr. 2007.
- [8] 3GPP LTE, <http://www.3gpp.org/article/lte>
- [9] IEEE 802.11, <http://www.ieee802.org/11/>
- [10] WiMAX, <http://www.wimaxforum.org/>
- [11] Q. H. Spencer, C. B. Peel, A. L. Swindlehurst, and M. Haardt, "An introduction to the multi-user MIMO downlink," *IEEE Communication Magazine*, vol.42, no.10, pp.60–67, Oct. 2004.
- [12] D. Gesbert, M. Kountouris, R. W. Heath Jr., C.-B. Chae, and T. Salzer, "Shifting the MIMO Paradigm," *IEEE Signal Processing Magazine*, vol.24, no.5, pp.36–46, Sept. 2007.
- [13] Y. Takatori and K. Nishimori, "Application of Downlink Multiuser MIMO Transmission Technology to Next Generation Very High

- Throughput Wireless Access Systems," IEICE Trans. Commun., Vol.J93-B, No9, pp.1127–1139, Sept. 2010.
- [14] K. Nishimori, *Basic Theory and Performance on Multi-user MIMO* (in Japanese), CORONA PUBLISHING CO., LTD., 2014.
- [15] G. Tsoulos, J. McGeehan and M. A. Beach, "Space Division Multiple Access (SDMA) Field Trials. Part 1: Tracking and BER Performance," IEE Proc. Radar, Sonar Navig., Vol.145, No.1, pp.73?78, Feb. 1998.
- [16] Y. Doi, J. Kitakado, T. Ito, T. Miyata, S. Nakao, T. Ohgane and Y. Ogawa, "Development and Evaluation of the SDMA Test Bed for PHS in the Field," IEICE Trans. Commun., Vol.E86-B, No.12, pp.3433–3440, Dec. 2003.
- [17] K. Nishimori and K. Cho, "Evaluation of SDMA employing vertical pattern and polarization control in actual cellular environment measurement," Proc. of IEEE VTC 2004-Spring, vol.1, pp.244–248, May 2004.
- [18] IEEE P802.11ac/D5.0, Part 11: Wireless LAN Medium Access Control (MAC) and Physical Layer (PHY) specifications.
- [19] E. Dahlman et. al., "LTE-Advanced - Evolving LTE towards IMT-Advanced," Proc. of VTC2008-Fall, Sept. 2008.
- [20] Q. H. Spencer, A. L. Swindlehurst, and M. Haardt, "Zero forcing methods for downlink spatial multiplexing in multiuser MIMO channels," IEEE Trans. Sig. Processing, vol.52, no.2, pp.461–471, Feb. 2004.
- [21] T. Ooka, N. Kikuma, and K. Sakakibara, "BER Performance of Block MSN Beamforming in Multi-User MIMO Transmission (in Japanese)," Tech. Rep. of IEICE, vol.116, no.7, A-P2016-11, pp.57–62, Apr. 2016.
- [22] K. Nishimori, T. Hiraguri, and H. Makino, "Transmission Rate by User Antenna Selection for Block Diagonalization Based Multiuser MIMO System," IEICE Trans. Commun., Vol.E97-B, No.10, pp.2118–2126, Oct. 2014.
- [23] M. H. M. Costa, "Writing on dirty paper," IEEE Trans. Information Theory, IT-29, pp.439–441, May 1983.
- [24] S. Vishwanath, N. Jindal, and A. Goldsmith, "Duality, Achievable Rates, and Sum-Rate Capacity of Gaussian MIMO Broadcast Channels," IEEE Trans. Information Theory, Vol.49, No.10, pp. 2658–2668, Oct. 2003.
- [25] Z. Shen, R. Chen, J. G. Andrews, R. W. Heath, Jr., and B. L. Evans, "Low complexity user selection algorithm for multiuser MIMO systems with block diagonalization," IEEE Trans. Signal Process., vol.54, no.9, pp.3658–3663, Sept. 2006.
- [26] M. Sadek, A. Tarighat and A. H. Sayed, "Active Antenna Selection in Multiuser MIMO Communications," IEEE Trans. Signal Process., vol.55, no.7, pp.1498–1510, Apr. 2007.
- [27] M. Tomlinson, "New automatic equaliser employing modulo arithmetic," Electronics Letters, vol.7, no.5/6, pp.138–139, Mar. 1971.
- [28] C. B. Peel, B. M. Hochwald, and A. L. Swindlehurst, "A vector-perturbation technique for near-capacity multiantenna multiuser communication : Part I: Channel inversion and regularization," IEEE Trans. Commun., vol.53, pp.195–202, Jan. 2005.
- [29] B. M. Hochwald, C. B. Peel, and A. L. Swindlehurst, "A vector perturbation technique for near capacity multiantenna multiuser communication : Part II: perturbation," IEEE Trans. Commun, vol.53, no.3, pp.537–544, Mar. 2005.
- [30] C. B. Chae, S. Shim, and R. W. Heath, Jr, "Block diagonalized vector perturbation for multiuser MIMO systems," IEEE Trans. Wireless Communications, vol.7, no.11, pp.4051–4057, Nov. 2008.
- [31] K. Nishimori, R. Kataoka, H. Makino, "Block Diagonalization with user antenna selection for multiuser MIMO systems," Proc. of 7th European Conference on Antennas and Propagation (EuCAP) 2013, pp.2118–2122, Apr. 2013.
- [32] F. Wang and M. E. Bialkowski, M. E, "Performance of multiuser MIMO system employing block diagonalization with antenna selection at mobile stations," Proc. of 2010 2nd International Conference on Signal Processing Systems (ICSPS), vol.1, pp.V1-671–V1-675, July 2010.
- [33] T. Sada, J. Webber, T. Nishimura, T. Ohgane, and Y. Ogawa, "A generalized approach to block diagonalization for multiuser MIMO downlink," Proc. of 2010 IEEE 21st International Symposium on Personal Indoor and Mobile Radio Communications (PIMRC), pp.504–509, Sept. 2010.
- [34] M. Gharavi-Alkhansari, A. B. Gershman, "Fast antenna subset selection in MIMO systems," IEEE Trans. on Signal Processing, vol.52, No.2, pp. 339–347, Feb. 2004.
- [35] T. Hiraguri and K. Nishimori, "Survey of Transmission Methods and Efficiency Using MIMO Technologies for Wireless LAN systems," IEICE Trans. Commun., Vol.E98-B, No.7, pp.1250–1267, July 2015.
- [36] A. Paulraj, R. Nabar, and D. Gore, "Introduction to space-time wireless communications," Cambridge University Press, 2003.
- [37] B. Widrow, P. E. Mantey, L. J. Griffiths, and B. B. Goode, "Adaptive Antenna Systems," Proc. IEEE, vol.55, no.12, pp.2143–2159, Dec. 1967.
- [38] J. B. Andersen, "Array gain and capacity for known random channels with multiple element arrays at both ends," IEEE J. Sel. Areas Commun., vol.18, No.11, pp.2172–2178, Nov. 2000.
- [39] K. Miyashita, T. Nishimura, T. Ohgane, Y. Ogawa, Y. Takatori, K. Cho, "High data-rate transmission with eigenbeam-space division multiplexing (E-SDM) in a MIMO channel," Proc. of Vehicular Technology Conference (VTC) 2002-Fall, vol.3, pp.1302–1306, Oct. 2002.
- [40] R. A. Monzingo, R. L. Haupt, and T. W. Miller, *Introduction to Adaptive Arrays* (2nd ed.), Scitech Pub Inc. 2010.
- [41] N. Kikuma and M. Fujimoto, "Adaptive Antennas," IEICE Trans. Communications, Vol.E86-B, No.3, pp.968–979, Mar. 2003.
- [42] R. T. Compton, Jr. : "The Power Inversion Adaptive Array : Concept and Performance," IEEE Trans. Aerosp. & Electron. Syst., vol.AES-15, No.6, pp.803–814, Nov. 1979.
- [43] S. P. Applebaum : "Adaptive Arrays", IEEE Trans. Antennas & Propag., vol.AP-24, No.5, pp.585–598, Sept. 1976.
- [44] K. Yonezu, N. Kikuma, and K. Sakakibara, "Improvement of Block Maximum SNR Algorithm by Adapted Pseudo-Noise in Multi-User MIMO Transmission (in Japanese)," Tech. Rep. of IEICE, vol.117, no.283, A-P2017-127, pp.103–108, Nov. 2017.
- [45] Rec. ITU-R P. 1238-4, P Series, 2005.
- [46] I. Sarris and A. R. Nix, "Design and performance assessment of high capacity MIMO architectures in the presence of a line-of-sight component," IEEE Trans. Vehicular Technology, Vol.56, no.4, pp.2194–2202, July 2007.
- [47] K. Nishimori, N. Honma, T. Seki and K. Hiraga, "On the Transmission Method for Short Range MIMO Communication," IEEE Trans. Vehicular Technology, Vol.60, no.3, pp.1247–1251, Mar. 2011.
- [48] E. G. Larsson, "Very large MIMO systems," ICASSP 2012 Tutorial.
- [49] F. Rusek, D. Persson, B. K. Lau, E. G. Larsson, T. L. Marzetta, O. Edfors, and F. Tufvesson, "Scaling up MIMO: Opportunities and challenges with very large MIMO," IEEE Signal Processing Magazine, pp.40–60, Jan. 2013.
- [50] L. Lu, "An Overview of Massive MIMO: Benefits and Challenges," IEEE Journal of Selected Topics in Signal Processing, Vol.8, No.5, pp.742–758, Oct. 2014.
- [51] J. Hoydis, S. T. Brink, and M. Debbah, "Massive MIMO in the UL/DL of cellular networks: How many antennas do we need?" IEEE Journal on Selected Areas in Communications, Vol.31, No.2, pp.160–171, Feb. 2013.
- [52] K. Kameyama, K. Nishimori, T. Hiraguri, H. Yamada and H. Makino, "Analog multi-beam massive MIMO transmission eliminating CSI estimation," IEICE Trans. Vol.J99-B, No.9, pp.743–752, Sept. 2016 (in Japanese Edition).
- [53] R. Taniguchi, K. Nishimori, and H. Makino, "Multi-Beam Massive MIMO using constant modulus algorithm for QAM signals employing amplitude and phase offset compensation," IEICE Commun., Vol.E100-B, No.2, pp.262–268, Feb. 2017.

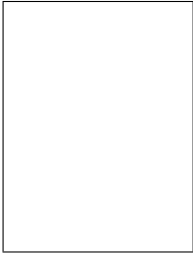

Nobuyoshi Kikuma received the B.S. degree in electronic engineering from Nagoya Institute of Technology, Japan, in 1982, and the M.S. and Ph.D. degrees in electrical engineering from Kyoto University, Japan, in 1984 and 1987, respectively. From 1987 to 1988, he was a Research Associate at Kyoto University. In 1988 he joined Nagoya Institute of Technology, where he has been a Professor since 2001. His research interests include adaptive and signal processing arrays, radio source localization, and MIMO technology for wireless communications and radar sensing. He received the 4th Telecommunications Advancement Foundation Award in 1989, IEICE Best Paper Award in 2005, and IEICE Educational Service Award in 2016. Dr. Kikuma is a senior member of the IEEE.

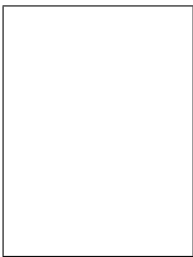

Kentaro Nishimori received the B.E., M.E. and Ph.D. degrees in electrical and computer engineering from Nagoya Institute of Technology, Nagoya, Japan in 1994, 1996 and 2003, respectively. In 1996, he joined the NTT Wireless Systems Laboratories, Nippon Telegraph and Telephone Corporation, in Japan. He is an Associate professor in Niigata University from 2009. He was a visiting researcher at Aalborg University, Aalborg, Denmark from Feb. 2006 to Jan. 2007. He received the Young Engineers Award from

the IEICE of Japan in 2001, Young Engineer Award from IEEE AP-S Japan Chapter in 2001. He received IEICE Best Paper Award in 2010. His main interests are spatial signal processing including massive MIMO systems. He is a member of IEEE.

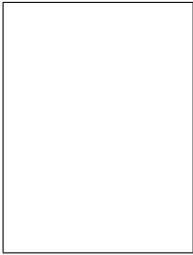

Takefumi Hiraguri received the M.E. and Ph.D. degrees from the University of Tsukuba, Ibaraki, Japan, in 1999 and 2008, respectively. In 1999, he joined the NTT Access Network Service Systems Laboratories, Nippon Telegraph and Telephone Corporation in Japan. He has been engaged in research and development of MAC protocol for the high speed and the high communication quality in wireless systems. He is now a Professor in Nippon Institute of Technology. He is a member of IEEE.